

RA 55|BM 60

RA 66|BM 60

RA 55|BM 60 iL

RA 66|BM 60 iL

**Ersatzteilliste
Reinigungsautomat**

**Spare parts list
Scrubber dryer**

**Catalogue des pièces de rechange
Auto-laveuse**

**Elenco pezzi di ricambio
Lavasciuga pavimenti**

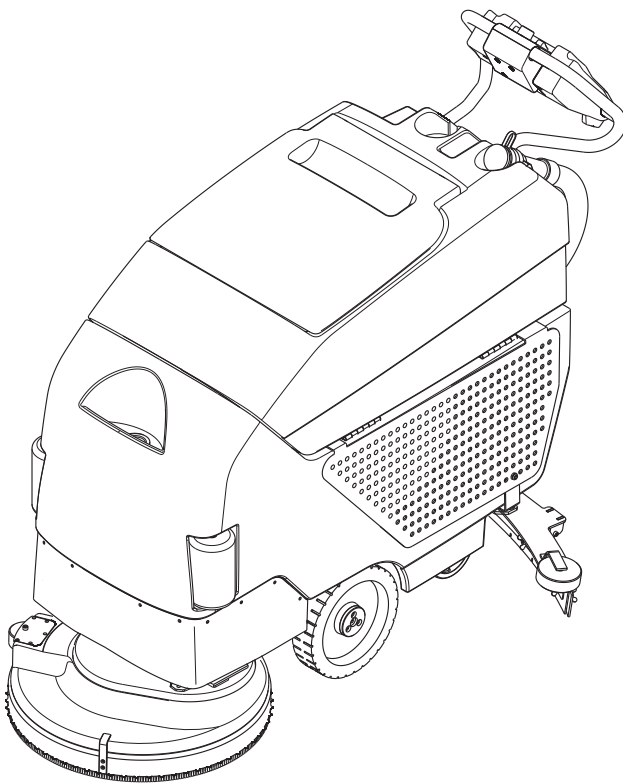

**RA 55|BM 60
RA 55|BM 60 iL**

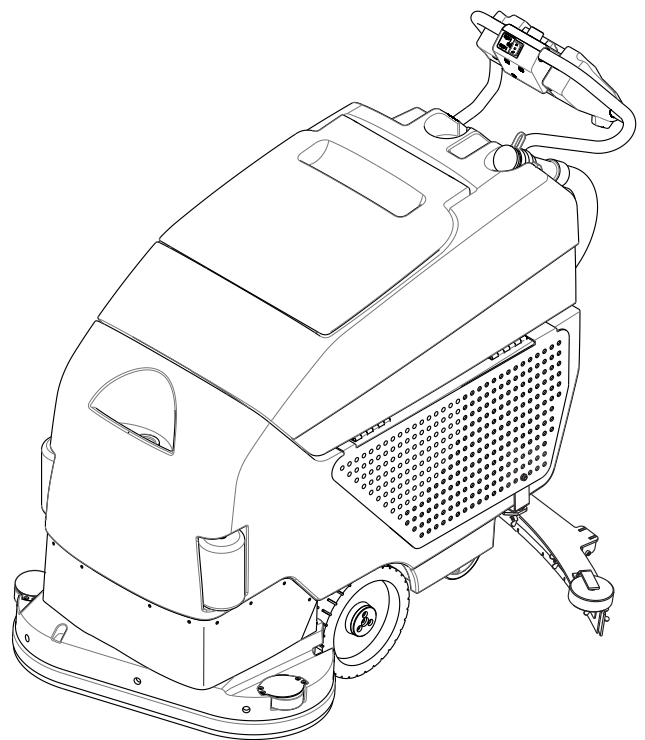

**RA 66|BM 60
RA 66|BM 60 iL**

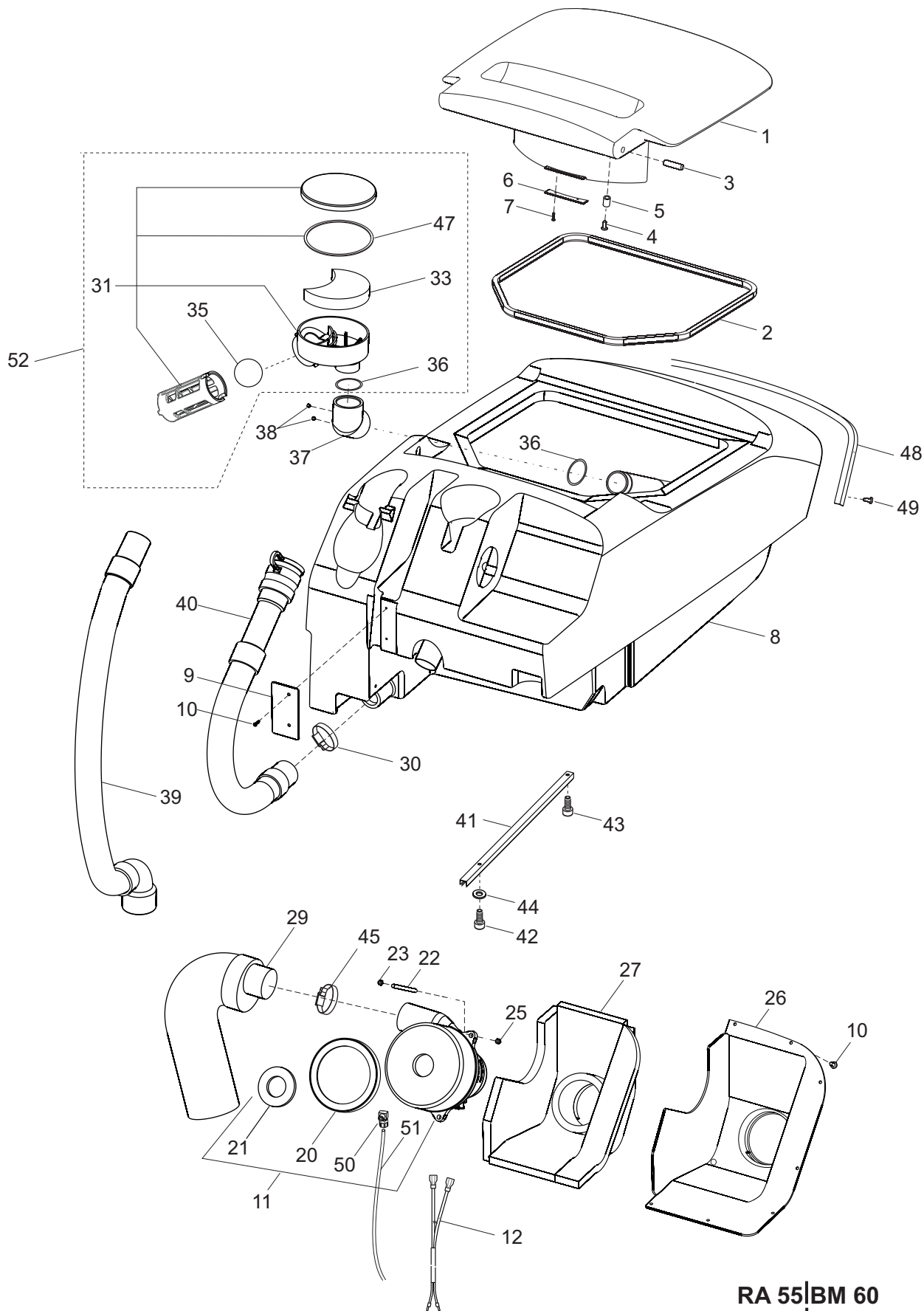

columbus

**RA 55|BM 60
RA 66|BM 60
RA 55|BM 60 iL
RA 66|BM 60 iL**

Schmutzwassertank

Pos.	Art. Nr.	Stück	Bezeichnung	Description	Designation	Descrizione
1	21050200	1	Tankdeckel, hellgrau	tank cover	Couvercle	coperchio
	21050202	1	Tankdeckel, weiß			
2	50798500	1,4m	Dichtprofil	band sealer	Joint	profilato di tenuta
3	20978400	2	Deckelbolzen	lid bolt	Boulon	bullone
4	20816200	2	Schraube KA 50x16 EJ schw	screw	Vis	vite KA 50x16
5	20938300	1	Distanzstück	spacer	Pièce d'écartement	distanziale
6	21059100	1	Tropfplatte	drip plate	Plaque-égouttoir	piastra
7	20828800	2	Blechschr.Li C 3,5x13 VA	screw	Vis	vite
8	21050100	1	SW-Tank, blau	recovery tank	Réservoir de récupération	serbatoio soluzione di recupero
	21050102	1	SW-Tank, weiß	recovery tank	Réservoir de récupération	serbatoio soluzione di recupero
9	21058400	1	Kabelabdeckung	cable cover	Protection de câble	blenda cavo
10	20625300	9	Schraube KA 50x12 schw. EJ	screw	Vis	vite
11	21415133	1	Saugaggregat 24/350 kpl.	suction motor	Moteur à aspiration	motore aspirazione
	20230536	1	Saugaggregat 36V silent kpl.	suction motor silent	Moteur à aspiration silent	motore aspirazione silent
12	21067800	1	Kabel Saugaggregat	cable for suction	Câble	cavo
20	20110600	1	Gummiring L-Form	gasket	Joint	guarnizione
21	20158800	1	Dichtung D60/D38x5 RA43-66	gasket	Joint	guarnizione
22	21038401	3	Gewindebolzen M6x90	threaded bolt	Tige filetée	perno filettato
23	20002000	3	6-Kantmutter M 6	hex.nut	Ecrou hexagonal	dado essag.
25	20070000	3	6-Kantmutter M 6 stopp	hex.nut	Ecrou hexagonal	dado essag.
26	21051300	1	Abdeckung Saugaggregat	motor cover	Calotte	blenda
27	21068100	1	Schalldämmung Saugaggregat	sound insulation	Amortisseur de bruit	isolamento acustico
29	20661030	1	Schalldämpfer	sound insulation	Amortisseur de bruit	silenziatore
30	20219700	1	Schlauchschelle W4 32-50/9	hose clamp	Collier	fascetta per tubi flessibili
31	21584430	1	Prefiltertopf kpl.	suction box	Pot d'aspiration	vaso aspirante
33	21061600	1	Prefilter	prefilter	Préfiltre	prefiltro
35	21058900	1	Ball Ø40	ball	Balle	palla
36	20063400	2	O-Ring 25x2	O-ring	Garniture	guarnizione
37	21059000	1	Fitting 63°	fitting 63°	coude 63°	fitting
38	20048300	2	Blechschr.Li C 2,9x6,5 VA	screw	Vis	vite
39	21525400	1	Saugschlauch NW38 L=770	suction hose	Flexible d'aspiration	tubo aspiratore
40	21525900	1	SW-Ablaufschlauch	drain hose	Tuyau de vidange	tubo di scarico
41	21072800	1	Kabelkanal L=480	cable duct	Protection de câble	
42	20279200	1	Zylinderschraube M 6x16	cylindrical head screw	Vis cylindrique	vite M6x16
43	20193000	1	Zylinderschraube M 6x10	cylindrical head screw	Vis cylindrique	vite M6x10
44	20096600	1	Dichtscheibe 6,8	sealing washer	Rondelle d'étanchéité	rondella
45	20219700	1	Schlauchschelle W4 32-50/9	hose clamp	Collier	fascetta per tubi flessibili
47	21075201	1	Rundschnurring D2/110	seal	Joint	guarnizione
48	51076500	0,8m	Gummi-Winkelprofil	band sealer	Joint	profilato di tenuta
49	20048300	20	Blechschr.Li C 2,9x6,5 VA	screw	Vis	vite
50	21252400	1	Winkelverschraubung	hose nozzle	Tubulure filetée	beccucio tubo fless.
51	50986300	1m	Schlauch 5x1,5	hose	Tuyau	tubo flessibile
52	21058837	1	Prefilter und Schwimmer	prefilter-floater	Préfiltre-floteur	prefiltro-galleggiante

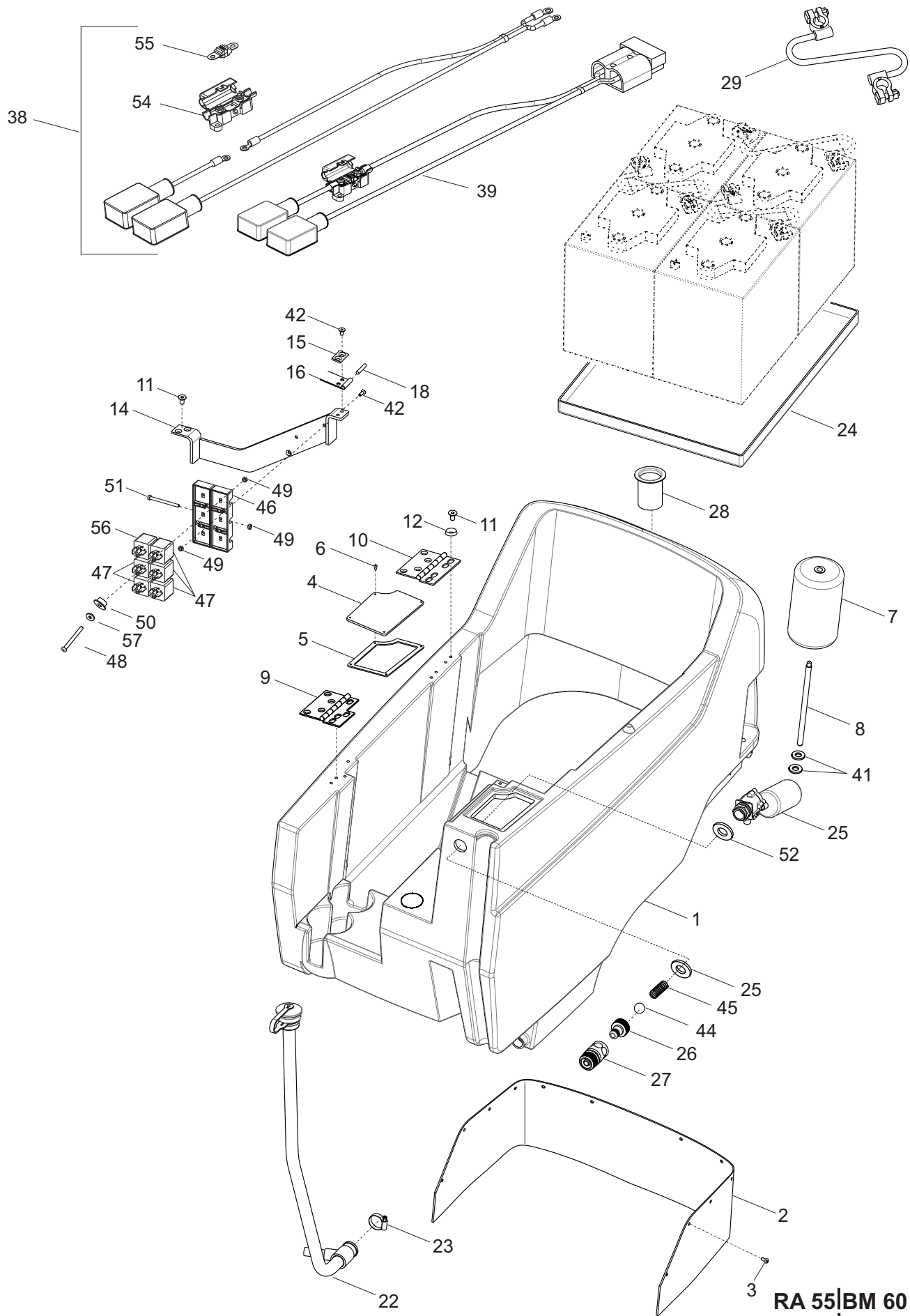

columbus

**RA 55|BM 60
RA 66|BM 60
RA 55|BM 60 iL
RA 66|BM 60 iL**

Frischwassertank

Pos.	Art. Nr.	Stück	Bezeichnung	Description	Designation	Descrizione
1	21050000	1	FW-Tank, blau	solution tank	Réservoir eau propre	serbatoio soluzione detergente
	21050002	1	FW-Tank, weiß	solution tank	Réservoir eau propre	serbatoio soluzione detergente
2	21054300	1	Blende FW-Tank	cover plate	bandeau	blenda
3	20625300	10	Schraube KA 50x12 schw. EJ	screw	Vis	vit
4	21054400	1	Deckel FW-Tank	cover	Couvercle	coperchio
5	21054500	1	Dichtung f.Deckel	seal	Joint	guarnizione
6	20132500	4	Blechschr.LiSenk C3,5x13vz	screw	Vis	vite
7	21032801	2	Abweisrolle FW-Tank	protecting caster	Roulette de protection	ruota di protezione
8	21032900	2	Achse f.Abweisrolle	axle	Axe	asse
9	20625401	1	Scharnier hinten	rear hinge	charnière arrière	cerniera
10	20625402	1	Scharnier vorne	front hinge	charnière à l'avant	cerniera
11	20636900	14	Senkschraube M 6x12	countersunk	Vis à tête noyée	vite
12	21160200	6	Rosette 6,5	rosette	Rosette	rosetta
14	21053300	1	Strebe FW-Tank	strut	Entretoise	montante
15	21053400	2	Platte Gurtband	plate	Plaque	piastra
16	51058200	0,5 m	Gurtband 30mm	strap	sangle	banda tessile
18	21062100	2	Zylinderstift 6x30	cylindrical pin	Groupille	caviglia
22	21526300	1	FW-Ablaufschlauch PU L=725	drain hose	Flexible de vidange	tubo scarico
23	20959400	1	Schlauchschelle W420-32/9	hose clamp	Collier	fascetta tubo flessibile
24	21054200	1	Batteriewanne	battery tray	Cuve	vasca
25	21058300	1	Schwimmer	float	Flotteur	galleggiante
26	21070800	1	Gardena-Hahnstück G3/4"	stop cock	robinet G3/4"	acqua stop
27	21070900	1	Gardena Wasserstopp	water stop	Arrêt automatique de l'eau type gardena	acqua stop
28	21033500	1	FW-Sieb	solution filter	Filtre eau fraîche	filtro soluzione detergente
29	21387400	3	Batterie-Verbindungskabel	batteries connection cable	câble	cavo collegamento - batterie
38	21064601	1	Batteriekabel iL	battery cable	Câble	cavo
39	21076800	1	Batteriekabel ext. LG	battery cable	Câble	cavo
41	20622600	4	Scheibe 13x24x2,5 PA	washer	Rondelle	rondella
42	21039800	6	Senkschraube M 5x16 schw	countersunk	Vis	vite
44	21155700	1	Kugel Ø13 PP	ball	balle	palla
45	21155800	1	Druckfeder VD-090U-12	tension spring	Ressort de compression	molla di compressione
46	21155500	2	Halter für Relais	support relay	Support relais	supporto relé
47	21452331	5	Relais klein mit 3 Kabeln	relay	Relais	relé
48	20037000	4	Zylinderschraube M5x40 VA	cylindrical-head screw	Vis cylindrique	vite a testa cilindrica
49	20574300	6	6-Kantmutter M 5 VA	hex.nut	Ecrou hexagonal	dado essag.
50	21450500	4	Haltescheibe	retaining washer	Rondelle	rondella
51	20380500	1	Zylinderschraube M5x60	cylindrical head screw	Vis cylindrique	vite
52	21172100	1	Gummidichtung 1/2"	seal	Joint	guarnizione
54	21387800	1	Sicherungshalter	fuse holder	Support fusible	supporto fusibile
55	21387900	1	Streifensicherung 100 A	fuse 100A	Fusible 100A	inserto fusibile
56	21452330	1	Relais klein mit 2 Kabeln	relay	Relais	relé
57	20183000	4	Scheibe 5,3x15,0x1,4	washer	Rondelle	rondella

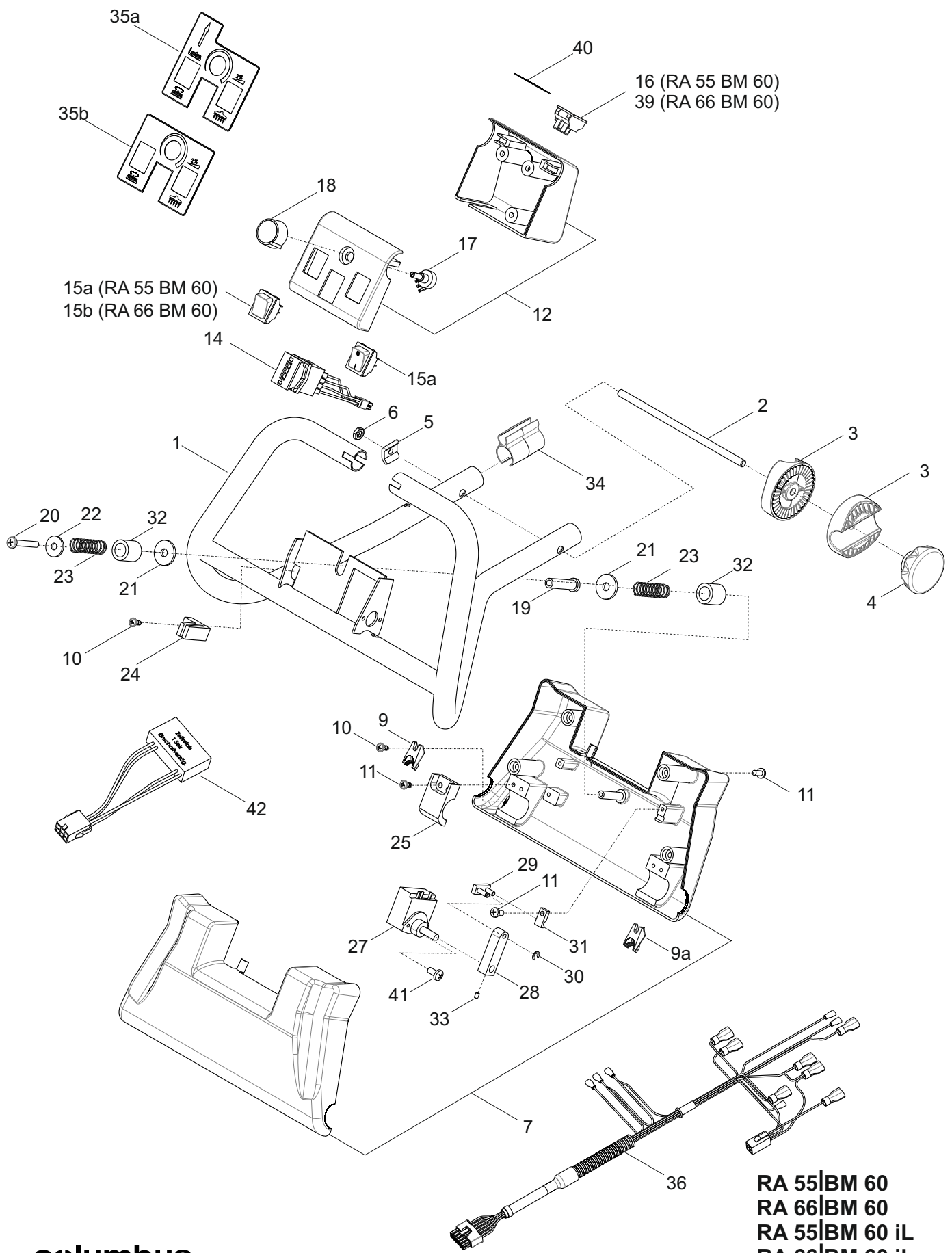

columbus

**RA 55|BM 60
RA 66|BM 60
RA 55|BM 60 iL
RA 66|BM 60 iL**

Griffbügel

Pos.	Art. Nr.	Stück	Bezeichnung	Description	Designation	Descrizione
1	21053000	1	Griffbügel	handle	Poignée	manico
2	21053100	1	Gewindestange	threaded bar	Tige fileté	asta filettata
3	20935800	4	Griffplatte	catch	Arrêt	attacco
4	20958500	1	Sterngriff M8	knob	Bouton	manopola
5	21053200	1	Prisma	prism	Prisme	prisma
6	20297300	1	6-Kantmutter M 8 Zn flach	hex.nut	Ecrou hexagonal	dado essag.
7	21059230	1	Wippe set	rocker set	Bascule set	bilanciere set
9	21070300	1	Schlauchklemmung	hose clamping	Collier de serrage	fascetta
9a	21079400	1	Schlauchklemmung rechts	hose clamping	Collier de serrage	fascetta
10	20625300	3	Schraube KA 50x12 schw. EJ	screw	Vis	vite
11	20816200	12	Schraube KA 50x16 EJ schw	screw	Vis	vite
12	21059430	1	Tastaturkasten set	panel set	Panneau set	tastieraset
14	20982100	1	Batteriewächter mit Kabel	battery charge indicator	Indication décharge de batterie	indicatore stato di carica
15a	20892400	2	Wippschalter mit Schutzkappe	switch	interrupteur	interruttore
15b	21064301	1	Wippschalter mit Schutzkappe	switch	interrupteur	interruttore
16	21154400	1	Blindabdeckung	blind cover	Couverture aveugles	coperchio cieco
17	21168700	1	Potentiometer 100KOhm-16	potentiometer 100KOhm	Potentiomètre 100KOhm	potenziometro 100KOhm
18	20425631	1	Potentiometer-Knopf	potentiometer button	Bouton potentiomètre	manopola potenziometro
19	21059600	1	Federführung	guidance for spring	Guide pour le ressort	guida per la molla
20	20236900	1	Schraube KA 50x50 EJ	screw	Vis	vite
21	20277800	2	Scheibe 9,0x28,0x3	washer	Rondelle	rondella
22	20112900	2	Scheibe 5,3x15,0x1,0 Zn	washer	Rondelle	rondella
23	21059700	2	Druckfeder D-090 Z	tension spring	Ressort de compression	molla di compressione
24	21059800	1	Führung	guidance	Guide	guida
25	21059900	2	Schelle groß	clamp	Serrage	morsetto
27	21060000	1	Potentiometer Wippe 5KOhm	potentiometer	Potentiomètre	potenziometro
28	21060100	1	Hebel 1	lever 1	Levier 1	leva 1
29	21060200	1	Hebel 2	lever 2	Levier 2	leva 2
30	20998400	1	Sicherungsscheibe VZ4	lock washer VZ4	Rondelle de sécurité VZ4	anello d'arresto VZ4
31	21060300	1	Schelle klein	clamp	Serrage	morsetto
32	21060400	2	Anschlag Feder	stopp für spring	Arrêter pour ressort	arresto per molla
33	20647200	1	Gewindestift M4x 6 Zn	headless screw M4x6	Goupille fileté M5x6	spina filettata M5x6
34	21070400	1	Schelle für Wellrohr	clamp	Serrage	morsetto
35a	70122301	1	Aufkleber Bedienfeld 55 (RA 55 BM 60)	operating label	autocollant avec instructions	etichetta die controllo
35b	70122302	1	Aufkleber Bedienfeld 66 (RA 66 BM 60)	operating label	autocollant avec instructions	etichetta die controllo
36	21061502	1	Kabelbaum Griff	cable tree	Harnais de câbles	albero cavo
37	21058500	1	Kabel Schalter Bürste	cable	Câble	cavo
39	21064201	1	Wipptaster mit Schutzkappe	switch	interrupteur	interruttore
40	70108400	1	Aufkleber Bürste aufnehmen-abwerfen	sticker	Autocollant	etichetta
41	20454200	2	Schraube KA 40x12 EJ	screw	Vis	vite
42	21078030	1	Zeitrelais	timing relay	Relais	relé

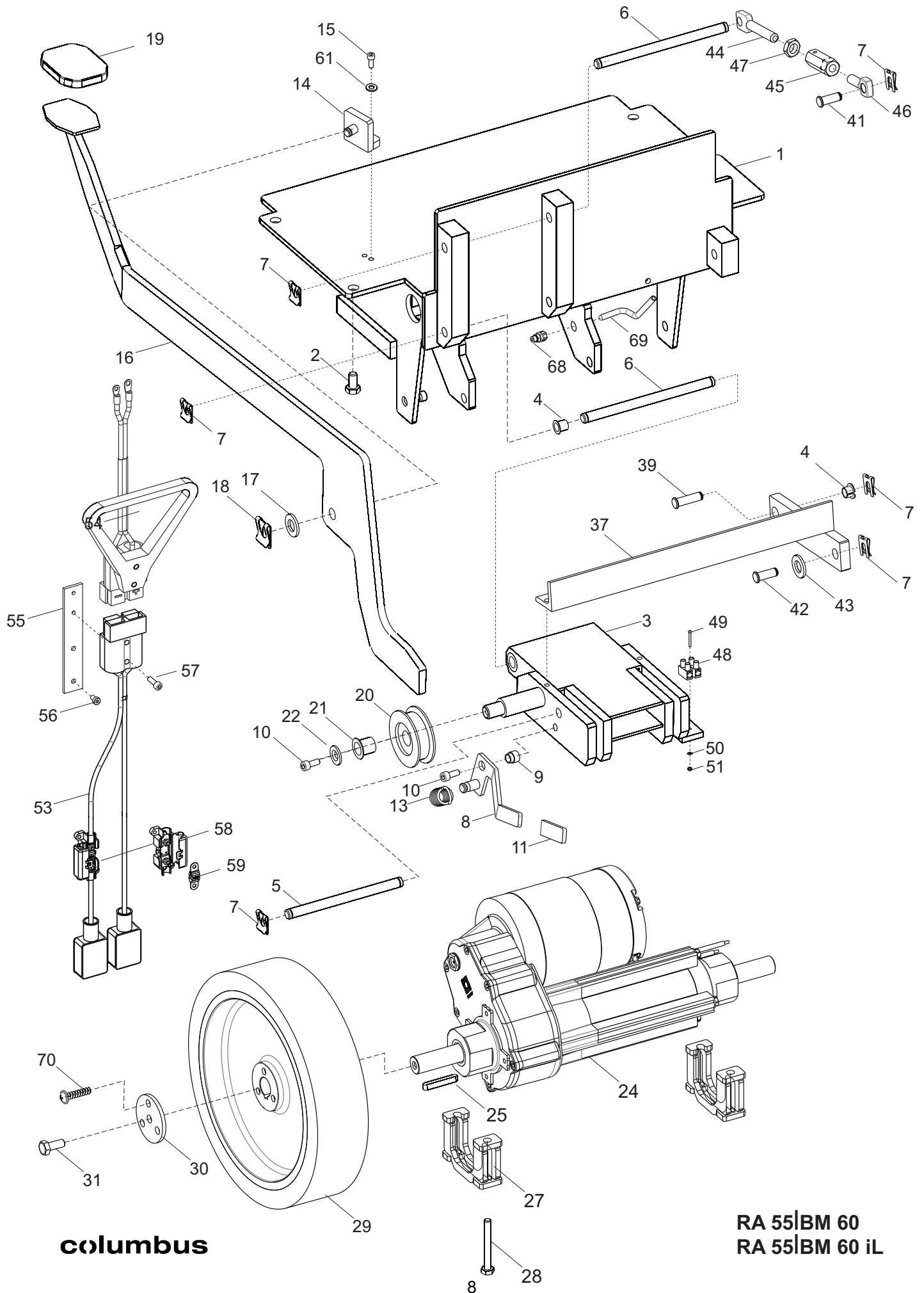

Chassis 55

Pos.	Art. Nr.	Stück	Bezeichnung	Description	Designation	Descrizione
1	21051600	1	Chassis	chassis	Chassis	telaio
2	20682200	4	Verbusschraube M 8x16	hex.screw	Ecrou hexagonal	vite
3	21051901	1	Parallelogramm	parallelogram	Parallélogramme	parallelogrammo
4	21067500	3	Bundbuchse BB1009DU	flange adaptor	douille à collet	camicia
5	21051801	1	Bolzen D10x125	bolt	Boulon	bullone
6	21053800	2	Bolzen D10x145	bolt	Boulon	bullone
7	20373900	6	SL-Sicherung 10	safety piece 10	Collier d'épaulement	pezzo di sicurezza
8	21052300	1	Hebel Bürstdruck	lever	Levier	leva
9	21070700	1	Buchse	bush	Brousse	boccola
10	20152000	1	Zylinderschraube M 8x16 Zn	cylindrical head screw	Vis cylindrique	vite
11	20188001	1	Flachkappe 3x15x80 RA	lever sheathing	protection du levier	ricoprimento leva
13	21058000	1	Zugfeder RZ 174 I	extension spring	Ressort de traction	molla di trazione
14	21066800	1	Winkel f.Fußpedal	support	Angle	angolo pedale
15	20279200	2	Zylinderschraube M 6x16 Zn	cylindrical head screw	Vis cylindrique	vite
16	21052200	1	Fußpedal	pedal	Pédale	pedale
17	20622600	1	Scheibe 13x24x2,5 PA	washer	Rondelle	rondella
18	20373800	1	SL-Sicherung 12	safety piece 12	Collier d'épaulement	pezzo di sicurezza
19	20816000	1	Pedal gummi f.Trittpedal	pedal rubber	Chaouchouc	gomma
20	21052000	1	Rolle	roller	Rôle	ruolo
21	20669400	1	Bundbuchse BB1417DU	flange adaptor	douille à collet	camicia
22	20633700	1	Scheibe 8,4x24x2	washer	Rondelle	rondella
24	21609500 21622610	1 1	Antriebseinheit Kohlenbürsten-Set	traction drive carbon brushes	entraînement charbons	motore trazione carboncino
25	20374400	2	Passfeder 6x6x40 VA	feather key	Ressort d'ajustage	linguetta di aggiustamento
27	21611300	2	Adapter-Halterung	support	Support	supporto
28	20588500	4	6-Kantschraube M6x65	hex.screw	Vis à tête hex.	vite
29	21519900 21519031	2	Rad Ø250 Option - weiches Rad	wheel Option - soft wheel	Roue en option - roue mou	ruota opzio.-ruota morbida
30	21523901	2	Radabdeckung (nur für Standardrad)	wheel cover (not for optional wheel)	Rondelle (seulement pour la roue standard)	blenda (solo per ruota standard)
31	20068001	2	6-Kantschraube M8x20 VA	hex.screw	Vis à tête hex.	vite
37	21066400	1	Bürstenhebel 55	lever	Levier de brosse	leva
38	20279200	2	Zylinderschraube M 6x16	screw	Vis cylindrique	vite
39	21067600	1	Bolzen mit Kopf	bolt	Boulon	bullone
41	20371803	1	Bolzen	bolt	Boulon	bullone
42	20371801	1	Bolzen	bolt	Boulon	bullone
43	20373700	1	Scheibe 10,5x20,0x2,0	washer	Rondelle	rondella
44	20980800	1	Schloßschraube M10 links	coach bolt M10 left	vis de tension M10 g.	tenditore a vite M10
45	20628001	1	Spannschloßmutter M10	barrel nut	tendeur	dado tenditore
46	20372601	1	Aufnahme f.Spannschloßm.	barrel nut fixing	Fixation d'écrou	attacco per dado
47	20054400	1	6-Kantmutter M10	hex.nut	Ecrou hexagonal	dado essag.
48	20409200	1	Klemmleiste 2-polig	clamping strip 2 pol	Borne de jonction	presa 2 pol
49	20114000	1	Linsenschraube M 3x25	lens screw M3x25	Vis à tête bombée	vite
50	20076400	1	Scheibe 4,3x12,0x1	washer	Rondelle	rondella
51	20011500	1	6-Kantmutter M 3 Zn	hex.nut	Ecrou hexagonal	dado essag.
52	20005500	1	Sicherungsscheibe SMZ 8	lock washer	Rondelle de sécurité	anello d'arresto
53	21076800	1	Batteriekabel ext. LG	battery cable	Câble	cavo
54	21076730	1	Batterie-Ladekabel ext. LG	battery charging cable	Câble	cavo di carica batteria
55	21077500	1	Halter für Batteriekabel	Support	Support	supporto
56	20193000	2	Zylinderschraube M 6x10	screw	Vis cylindrique	vite

Chassis 55

Pos.	Art. Nr.	Stück	Bezeichnung	Description	Designation	Descrizione
57	20579600	2	Zylinderschraube M 6x30 VA	cylindrical head screw	Vis cylindrique	vite
58	21387800	1	Sicherungshalter	fuse holder	Support fusible	supporto fusibile
59	21387900	1	Streifensicherung 100A	fuse 100A	Fusible 100A	inserto fusibile
61	20008000	2	Sicherungsscheibe SMZ 6	lock washer	Rondelle de sécurité	rondella di sicurezza
62	20113000	2	Scheibe 6,4	washer	Rondelle	rondella
68	21252500	1	Geradeverschraubung	hose nozzle	Tubulure filetée	beccucio tubo fless.
69	50986300	1m	Schlauch 5x1,5	hose	Tuyau	tubo flessibile
70	20561200	6	Schraube KA 70x30 EJ	screw KA 70x30 EJ	Vis KA 70x30 EJ	vite KA 70x30 EJ

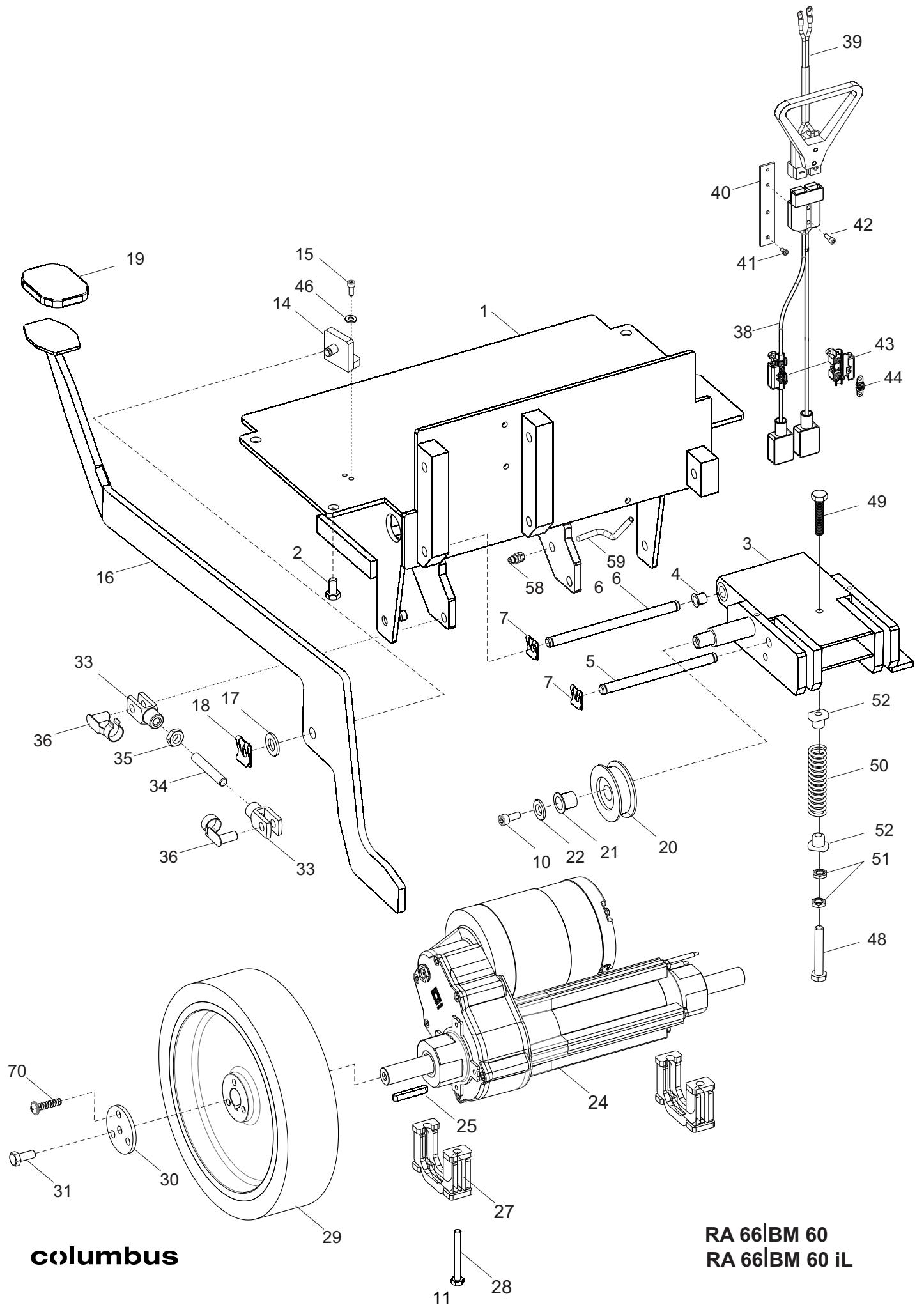

columbus

**RA 66|BM 60
RA 66|BM 60 iL**

Chassis 66

Pos.	Art. Nr.	Stück	Bezeichnung	Description	Designation	Descrizione
1	21051600	1	Chassis	chassis	Chassis	telaio
2	20682200	4	Verbusschraube M 8x16	hex.screw	Ecrou hexagonal	vite
3	21051901	1	Parallelogramm	parallelogram	Parallélogramme	parallelogrammo
4	21067500	3	Bundbuchse BB1009DU	flange adaptor	douille à collet	camicia
5	21051801	1	Bolzen D10x125	bolt	Boulon	bullone
6	21053800	1	Bolzen D10x145	bolt	Boulon	bullone
7	20373900	4	SL-Sicherung 10 MBO 08	safety piece 10	Collier d'épaulement	pezzo di sicurezza
10	20152000	1	Zylinderschraube M 8x16	head screw	Vis cylindrique	vite
14	21066800	1	Winkel f.Fußpedal	support	Angle	angolo pedale
15	20279200	2	Zylinderschraube M 6x16	cylindrical head screw	Vis cylindrique	vite
16	21052200	1	Fußpedal	pedal	Pédale	pedale
17	20622600	1	Scheibe 13,0x24,0x2,5 PA	washer	Rondelle	rondella
18	20373800	1	SL-Sicherung 12 MBO 08	safety piece 12	Collier d'épaulement	pezzo di sicurezza
19	20816000	1	Pedal gummi f.Trittpedal	pedal rubber	Chaouchouc	gomma
20	21052000	1	Rolle	roller	Rôle	boccola
21	20669400	1	Bundbuchse BB1417DU	flange adaptor	douille à collet	camicia
22	20633700	1	Scheibe 8,4x24x2	washer	Rondelle	rondella
24	21609500	1	Antriebseinheit	traction drive	entraînement	motore trazione
	21622610	1	Kohlenbürsten-Set	carbon brushes	charbons	carboncino
25	20374400	2	Passfeder 6x6x40 VA	feather key	Ressort d'ajustage	linguetta di aggiustamento
27	21611300	2	Adapter-Halterung	support	Support	supporto
28	20588500	4	6-Kantschraube M6x65	hex.screw	Vis à tête hex.	vite
29	21519900 21519031	2	Rad Ø250 Option - weiches Rad	wheel Option - soft wheel	Roue en option - roue mou	ruota opzio.-ruota morbida
30	21523901	2	Radabdeckung (nur für Standardrad)	wheel cover (not for optional wheel)	Rondelle (seulement pour la roue standard)	blenda (solo per ruota standard)
31	20068001	2	6-Kantschraube M8x20 VA	hex.screw	Vis à tête hex.	vite
33	20627200	4	Gabelkopf G10x20	fork set screw G10x20	Tête à fourche G10x20	vite a forcella G10x20
34	21061300	2	Gewindestange M10	screwed bar M10	Tige filetée	asta filettata M10
35	20054400	1	6-Kantmutter M10	hex.nut	Ecrou hexagonal	dado essag.
36	20631000	4	Federklappbolzen 10x20	snap-on clip 10x20	Étrier de ressort 10x20	bullone 10x20
38	21076800	1	Batteriekabel ext. LG	battery cable	Câble	cavo
39	21076730	1	Batterie-Ladekabel ext. LG	battery charging cable	Câble	cavo di carica batteria
40	21077500	1	Halter für Batteriekabel	support	Support	supporto
41	20193000	2	Zylinderschraube M 6x10	cylindrical head screw	Vis cylindrique	vite
42	20579600	2	Zylinderschraube M 6x30 VA	cylindrical head screw	Vis cylindrique	vite
43	21387800	1	Sicherungshalter	fuse holder	Support fusible	supporto fusibile
44	21387900	1	Streifensicherung 100A	fuse 100A	Fusible 100A	inserto fusibile
46	20008000	2	Sicherungsscheibe SMZ 6	lock washer	Rondelle de sécurité	rondella di sicurezza
48	21166500	1	6-Kantschraube M10x65 VA	hex.head screw	Vis à tête hex.	vite a testa esagonale
49	20141901	1	6-Kantschraube M10x50 VA	hex.head screw	Vis à tête hex.	vite a testa esagonale
50	20761101	1	Druckfeder VD-308A-04	pression spring	Ressort	molla di pressione
51	20626400	2	6-Kantmutter M10 flach VA	hex.nut	écrou hexagonal	dado esagonale
52	21166400	2	Federführung	spring guide	Guidage	guida
68	21252500	1	Geradeverschraubung	hose nozzle	Tubulure filetée	beccucio tubo fless.
69	50986300	1m	Schlauch 5x1,5	hose	Tuyau	tubo flessibile
70	20561200	6	Schraube KA 70x30 EJ	screw KA 70x30 EJ	Vis KA 70x30 EJ	vite KA 70x30 EJ

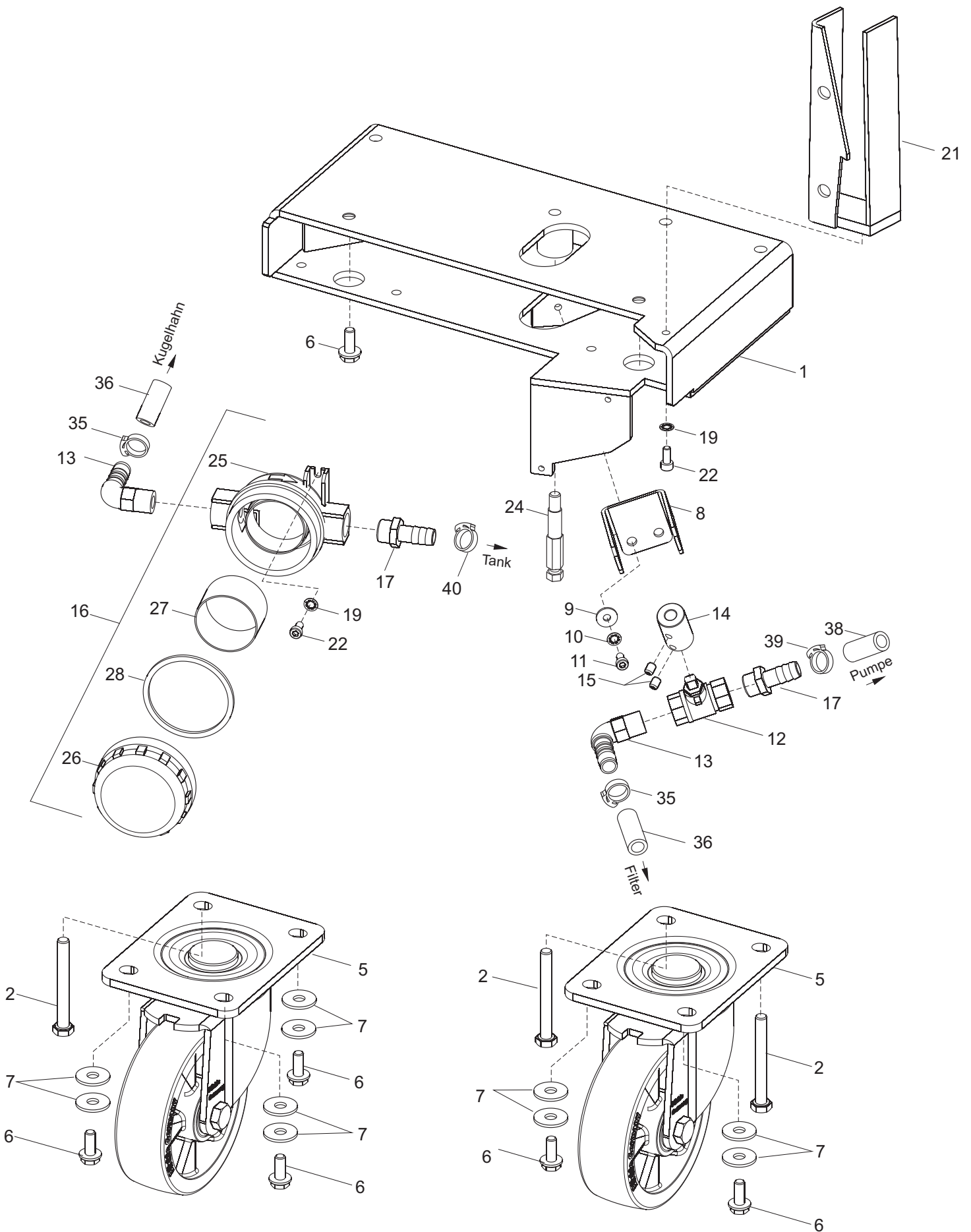

columbus

**RA 55|BM 60
RA 66|BM 60
RA 55|BM 60 iL
RA 66|BM 60 iL**

Traverse

Pos.	Art. Nr.	Stück	Bezeichnung	Description	Designation	Descrizione
1	21052400	1	Traverse	traverse	Traverse	Attraversa
2	20705800	3	6-Kantschraube M 8x75	hex.screw	Vis à tête hex.	vite
5	21058100 21519100	2	Lenkrolle D125 Option-Lenkrolle weich	caster Ø125 option-soft caster	Poulie-guide en option-poulie mou	rullo di guida opzio.- rullo morbido
6	20682200	7	Verbusschraube M 8x16	hex.screw	Vis à tête hex.	vite
7	20633700	10	Scheibe 8,4x24,0x2	washer	Rondelle	rondella
8	21052700	1	Ventilhalter	valve holder	Support Valve	supporto valvola
9	20113000	2	Scheibe 6,4	washer	Rondelle	rondella
10	20008000	4	Sicherungsscheibe SMZ 6	lock washer SMZ6	Rondelle de sécurité SMZ6	anello d'arresto SMZ6
11	20193000	4	Zylinderschraube M 6x10	cylindrical head screw	Vis cylindrique	vite
12	21033200	1	Kugelhahn 3/8"-D10 Ms/Ni	ball cock	robinet à bille	rubinetto dell'acqua
13	20671000	2	Winkel-Einschraubstutzen	hose nozzle	Tubulure filetée	beccucio tubo flessibile
14	21033303	1	Kupplung mit Anschlag	attachment	Couplage	giunto
15	20404000	2	Gewindestift M6x 8 Zn	stud M6x8	Boulon filetée	perno filettato
16	20760700	1	Filter Inline 3/8"	filter	Filtre	filtro
17	20681400	2	Schlauchtülle 3/8"	hose nozzle	Tubulure filetée	beccucio tubo flessibile
19	20067400	3	Sicherungsscheibe SMZ 5	lock washer	Rondelle de securité	rondella di sicurezza
21	21052800	1	Kulisse	connecting link	coulisse	
22	20149200	3	Zylinderschraube M 5x12 VA	cylindrical head screw	Vis cylindrique	vite
24	21052601	1	Bolzen Düsenhalter	bolt	Boulon	bullone
25	20866100	1	Unterteil	lower part	Corp	parte inferiore
26	20815800	1	Schraubkappe	scewed cover	Calotte vissée	cappello filettato
27	20815700	1	Filtereinsatz	filter insert	Elément filtrante	elemento filtrante
28	21158700	1	Formdichtung	gasket	Garniture	guarnizione
35	20272500	2	Schlauchschelle W4 12-22/9	hose clamp	Collier	fascetta tubo flessibile
36	50680800	0,110 m	PVC-Gewebes Schlauch Ø13x3	hose	Tuyau	tubo flessibile
38	50020600	0,87m	Drahtspiralschlauch Ø13x3	hose	Tuyau	tubo
39	20272500	1	Schlauchschelle W412-22/9	hose clamp	Collier	fascetta tubo flessibile
40	20959600	1	Schlauchschelle W4 8-16/9	hose clamp	Collier	fascetta tubo flessibile

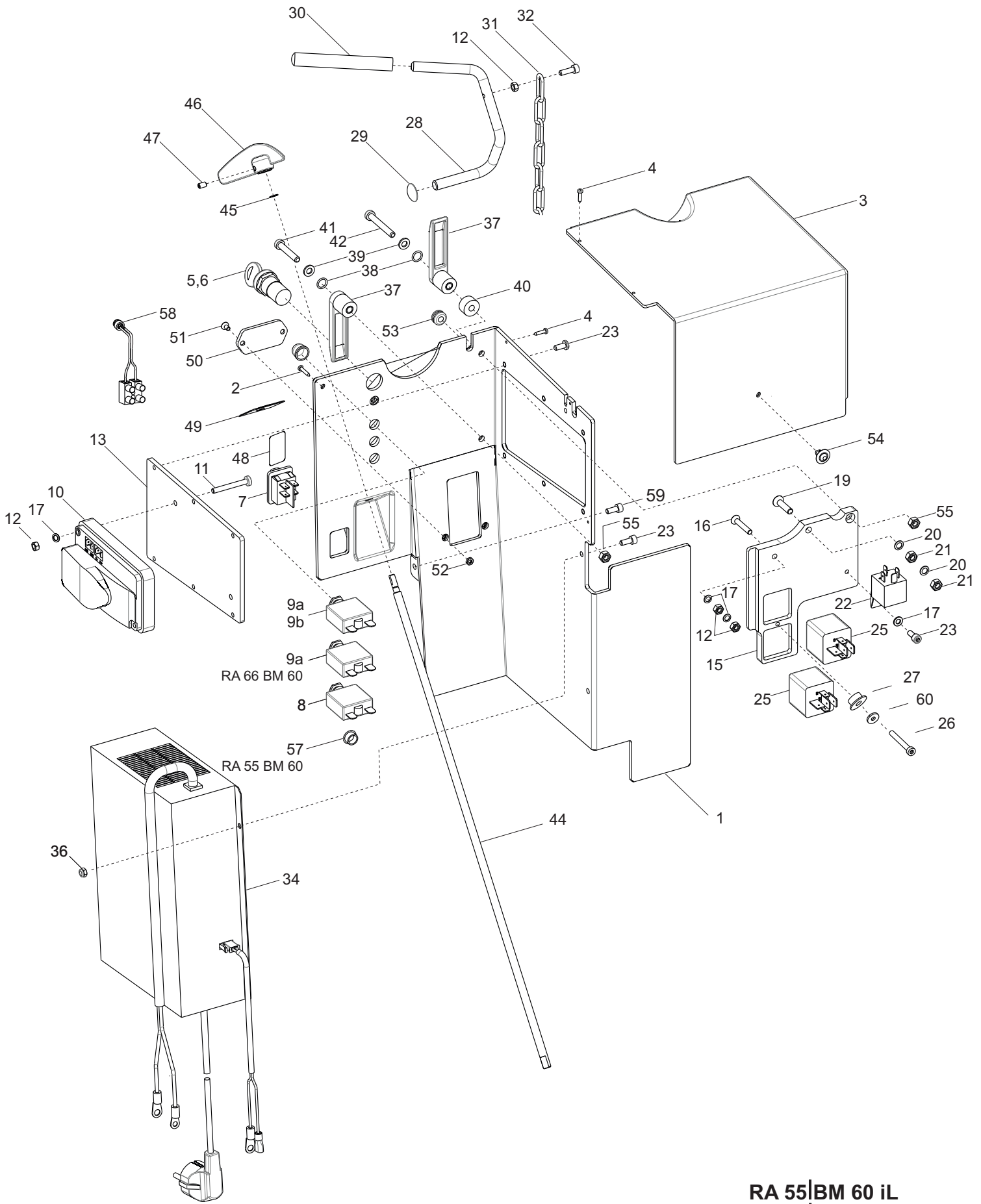

columbus

**RA 55|BM 60 iL
RA 66|BM 60 iL**

Elektrik iL

Pos.	Art. Nr.	Stück	Bezeichnung	Description	Designation	Descrizione
1	21156300	1	Rückwand iL	electric box	Electrochaisse	elettrocassetta
2	21077700	1	Spanplattenschraube 4x30	screw	Vis	vite
3	21060700	1	Elektro Deckel	cover	Couvercle	coperchio
4	20828800	4	Blechschr.Li C 3,5x13 VA	screw	Vis	vite
5	20632500	1	Schlüsselschalter SPE	key switch	Commutateur à clé	interruttore a chiave
6	20632501	1	Ersatz-Schlüssel	key	Clé	chiave
7	20892400	1	Wippschalter	rocker switch	Interrupteur à bascule	interruttore
8	20202401	1	Überstromschutzsch.30A	fuse 30A	Fusible 30A	fusibile
9a	21374300	2	Überstromschutzsch.15A (RA 66 BM 60)	fuse 15A	Fusible 15A	fusibile
9b	21077800	1	Überstromschutzsch.25A (RA 55 BM 60)	fuse 25A	Fusible 25A	fusibile
10	21060801	1	Fahrsteuerung 24V 70A	speed control	Contrôle de la vitesse	controllo della velocità
11	20203300	2	Linsenschraube M 5x30	lens screw	Vis à tête bombée	vite
12	20574300	5	6-Kantmutter M 5 VA	hex.nut	Ecrou hexagonal	dado essag.
13	21156200	1	Kühlblech	cooling plate	Dissipateur	dissipatore
15	21156100	1	Isolierplatte Pole	isolation plate	Plaque d'isolation	piastra isolante
16	20067800	1	Senkschraube M 5x35 VA	countersunk	Vis à tête noyée	vite
17	20067400	5	Sicherungsscheibe SMZ 5 VA	lock washer	Rondelle de securité	rondella di sicurezza
19	21076400	1	Senkschraube M 6x30	countersunk	Vis à tête noyée	vite
20	20008000	2	Sicherungsscheibe SMZ 6	lock washer	Rondelle de securité	rondella di sicurezza
21	20002000	2	6-Kantmutter M 6 VA	hex.nut	Ecrou hexagonal	dado essag.
22	20982800	1	Leistungsrelais Schließer	relay	Relais	relé
23	20003200	9	Linsenschraube M 5x8	lens screw	Vis à tête bombée	vite
25	21452330	2	Relais klein mit 2 Kabeln	relay	Relais	relé
26	20224600	1	Zylinderschraube M 5x30	screw	Vis cylindrique	vite a testa cilindrica
27	21450500	1	Haltescheibe	retaining washer	Rondelle	rondella
28	21061000	1	Saugdüsenhebel	lever	Levier	leva
29	20959000	1	Federscheibe mit Kappe D10	spring washer	Rondelle	rondella elastica
30	20894000	1	Überzug Saugdüsenhebel	lever sheathing	Revêtement de protection	ricoprimento leva
31	50630200	0,58m	Kette 3x26 V2A	chain	Châine	cerniera
32	20061500	1	Zylinderschraube M 5x16	screw	Vis cylindrique	vite
34	21061800	1	Ladegerät 20A	batterie charger 20A	Chargeur 20A	caricabatteria 20A
	21061801	1	Ladegerät 20A (mit 3-pol Stecker Australien)	batterie charger 20A (with 3-pin plug Australia)	Chargeur 20A (avec prise à 3 broches Australie)	caricabatteria 20A (con connettore a 3 pin Australia)
36	20046000	2	6-Kantmutter M 5 stopp VA	hex.nut	Ecrou hexagonal	dado essag.
37	20319600	2	Kabelhaken	cable hook	crochet pour câble	gancio
38	20930900	2	O-Ring 8,5x1,5	O-ring	O-ring	guarnizione
39	20000700	2	Scheibe 6,4x12,0x1,5	washer	Rondelle	rondella
40	21155400	1	Distanzstück D18/d6,4x10	distancer	Distancier	distanziatore
41	20831600	1	Zylinderschraube M 6x35	screw	Vis cylindrique	vite
42	20932000	1	Zylinderschraube M 6x45	screw	Vis cylindrique	vite
44	21052901	1	FW-Dosierstange	bar	Tige	barra
45	20069200	1	Sicherungsscheibe VZ5 VA	lock washer	Rondelle de securité	rondella di sicurezza
46	20647100	1	Zeigerknopf f.Wasserdosier	index button	Boutton	manopola indicatore
47	20927800	1	Gewindestift M5x 8 VA	headless screw M5x8	Goupille filetée M5x8	perno filettato
48	70088901	1	Aufkleber Fahren-Schieben	sticker	Autocollant	etichetta
49	70108200	1	Aufkleber WD	sticker	Autocollant	etichetta
50	21079300	1	Abdeckplatte	cover	Couvrir	copertura
51	20011101	2	Senkschraube M4x8 VA	countersunk	Vis à tête noyée	vite
52	20000200	2	6-Kantmutter M4 Ms flach	hex.nut	Ecrou hexagonal	dado essag.
53	21161900	1	Kabeldurchführungsstülle	cable sleeve		
54	20281100	1	Schraubenniet Ø6x11 PA	rivet	Rivet	rivetto

Elektrik iL

Pos.	Art. Nr.	Stück	Bezeichnung	Description	Designation	Descrizione
55	20070000	2	6-Kantmutter M 6 STOPP VA	hex.nut	Ecrou hexagonal	dado essag.
57	21160600	1	Stopfen	stopper	Bouchon	tappo
58	21159030	1	LED gelb	LED	LED	LED
59	20278000	1	Linsenschraube M5x12	lens screw	Vis à tête bombée	vite
60	20183000	1	Scheibe 5,3x15,0x1,4	washer	Rondelle	rondella

Elektrik

Pos.	Art. Nr.	Stück	Bezeichnung	Description	Designation	Descrizione
1	21156302	1	Rückwand	electric box	Electrochaise	elettrocassetta
2	21077700	1	Spanplattenschraube 4x30	screw	Vis	vite
3	21060700	1	Elektro Deckel	cover	Couvercle	coperchio
4	20828800	4	Blechschr.Li C 3,5x13 VA	screw	Vis	vite
5	20632500	1	Schlüsselschalter SPE	key switch	Commutateur à clé	interruttore a chiave
6	20632501	1	Ersatz-Schlüssel	key	Clé	chiave
7	20892400	1	Wippschalter	rocker switch	Interrupteur à bascule	interruttore
8	20202401	1	Überstromschutzsch.30A	fuse 30A	Fusible 30A	fusibile
9a	21374300	2	Überstromschutzsch.15A (RA 66 BM 60)	fuse 15A	Fusible 15A	fusibile
9b	21077800	1	Überstromschutzsch.25A (RA 55 BM 60)	fuse 25A	Fusible 25A	fusibile
10	21060800	1	Fahrsteuerung 24V 70A	speed control	Contrôle de la vitesse	controllo della velocità
11	20203300	2	Linsenschraube M 5x30	lens screw	Vis à tête bombée	vite
12	20574300	5	6-Kantmutter M 5 V2A	hex.nut	Ecrou hexagonal	dado essag.
13	21156200	1	Kühlblech	cooling plate	Dissipateur	dissipatore
15	21156100	1	Isolierplatte Pole	isolation plate	Plaque d'isolation	piastra isolante
16	20067800	1	Senkschraube M 5x35 VA	countersunk	Vis à tête noyée	vite
17	20067400	5	Sicherungsscheibe SMZ 5 VA	lock washer	Rondelle de securité	rondella di sicurezza
19	21076400	2	Senkschraube M 6x30	countersunk	Vis à tête noyée	vite
20	20008000	2	Sicherungsscheibe SMZ 6	lock washer	Rondelle de securité	rondella di sicurezza
21	20002000	2	6-Kantmutter M 6 VA	hex.nut	Ecrou hexagonal	dado essag.
22	20982800	1	Leistungsrelais Schließer	relay	Relais	relé
23	20003200	7	Linsenschraube M 5x8	lens screw	Vis à tête bombée	vite
25	21077300	2	Relais m.Diode Umschalter	relay	Relais	relé
26	20224600	1	Zylinderschraube M 5x30 VA	cylindrical-head screw	Vis cylindrique	vite a testa cilindrica
27	21450500	1	Haltescheibe	retaining washer	Rondelle	rondella
28	21061000	1	Saugdüsenhebel	lever	Levier	leva
29	20959000	1	Federscheibe mit Kappe D10	spring washer	Rondelle	rondella elastica
30	20894000	1	Überzug Saugdüsenhebel	lever sheathing	Revêtement de protection	ricoprimento leva
31	50630200	0,58m	Kette 3x26 V2A	chain	Chaîne	cerniera
32	20061500	1	Zylinderschraube M 5x16 Zn	cylindrical head screw	Vis cylindrique	vite
44	21052901	1	FW-Dosierstange	bar	Tige	barra
45	20069200	1	Sicherungsscheibe VZ5 VA	lock washer	Rondelle de securité	rondella di sicurezza
46	20647100	1	Zeigerknopf f.Wasserdosier	index button	Boutton	manopola indicatore
47	20927800	1	Gewindestift M5x 8 VA	headless screw M5x8	Goupille fileté M5x8	perno filettato
48	70088901	1	Aufkleber Fahren-Schieben	sticker	Autocollant	etichetta
49	70108200	1	Aufkleber WD	sticker	Autocollant	etichetta
54	20281100	1	Schraubenniet Ø6x11 PA	rivet	Rivet	rivetto
55	21039800	1	Sebkschraube M5x16 schw.	countersunk	Vis à tête noyée	vite
56	20543800	1	Gewindebuchse M5	threaded busch	Douille filletée	boccola filettata
57	21160600	1	Stopfen	stopper	Bouchon	tappo
58	21159030	1	LED gelb	LED	LED	LED
59	20278000	1	Linsenschraube M5x12	lens screw	Vis à tête bombée	vite
60	20183000	1	Scheibe 5,3x15,0x1,4	washer	Rondelle	rondella

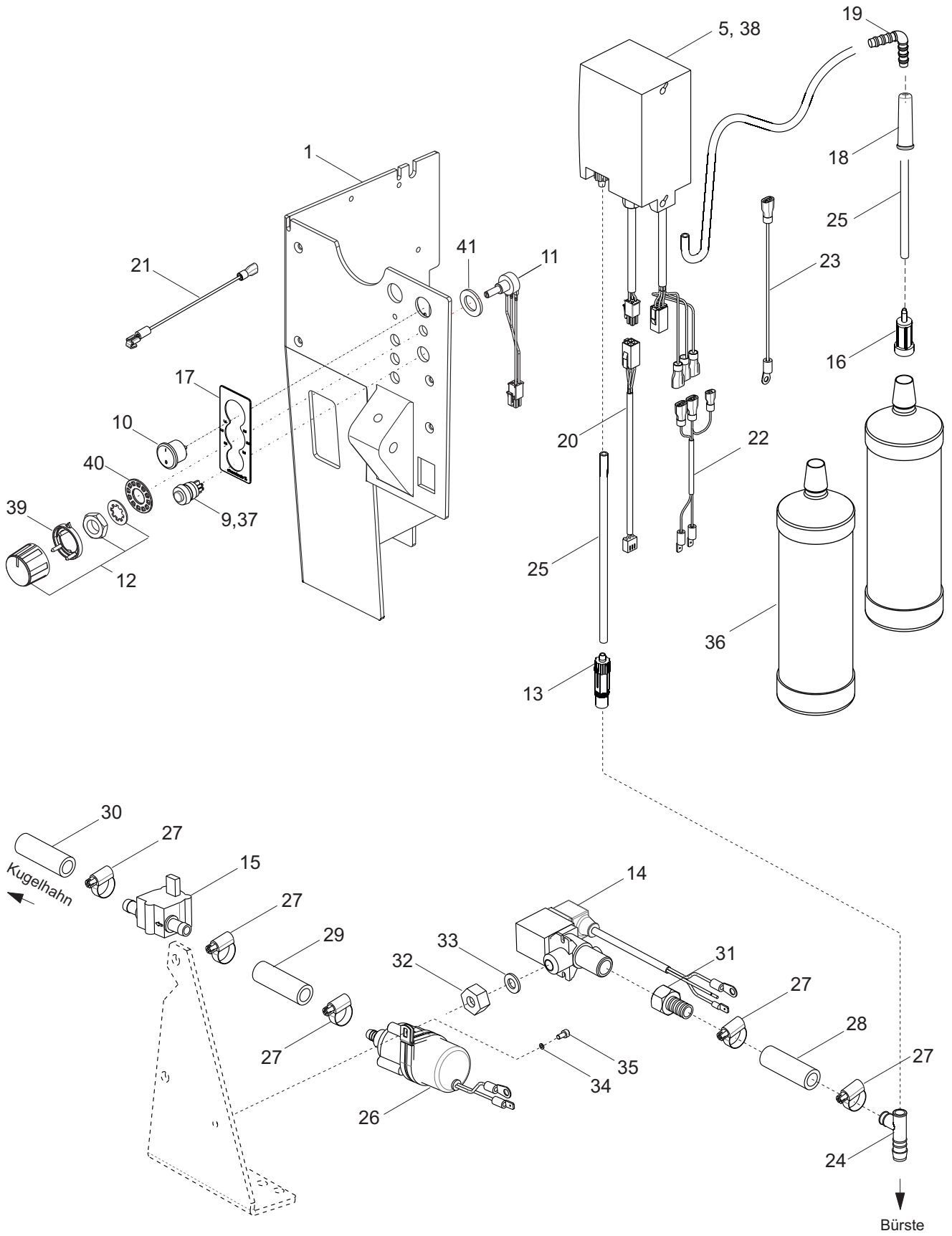

columbus

**RA 55|BM 60
RA 55|BM 60 iL**

Chemiedosierung 55

Pos.	Art. Nr.	Stück	Bezeichnung	Description	Designation	Descrizione
1	21156301	1	Rückwand iL Chemiedosierung	electric box	électrocaisse	elettrocassetta
	21156303	1	Rückwand Chemiedosierung	electric box	électrocaisse	elettrocassetta
5	20970600	1	Chemie-Pumpe C0059-1	pump for chemistry	Pompe pour la chimie	pompa per la chimica
9	20369100	1	Druckknopfschalter	push-button switch	Commutateur	interruttore a pulsanze
10	21044000	1	Wippschalter rund Ein-Aus	switch	Interrupteur	interruttore
11	21168730	1	Potentiom.100KOhm-16 Kabel	potentiometer	Potentiomètre	potenziometro
12	21168830	1	Potentiometer-Knopf	potentiometer button	Bouton potentiomètre	manopola potenziometro
13	20970800	1	Rückschlagventil Chemie	retention valve	valve de retenue	valvola antiritorno
14	21055000	1	Magnetventil	magnetic valve	Electrovalve	elettrovalvola
15	20970700	1	Durchlaufmesser	flow indicator	débitmètre	flussometro
16	20405300	1	FW-Filter	filter	filtre	filtro
17	70108300	1	Aufkleber Chemiedosierung	sticker	Autocollant	etichetta
18	21046400	2	Knickschutztülle D9	grommet	Buchon pour cable	passacavo
19	21041800	1	Verbindungsstutzen	hose nozzle	Tubulure fileté	beccocio tubo flessibile
20	21041400	1	Kabel Pumpe-Durchlaufm.	cable	Câble	cavo
21	21069800	1	Kabel zu Schlüsselschalter	cable	Câble	cavo
22	21069900	1	Kabel Chemie-Pumpe	cable	Câble	cavo
23	21070000	1	Kabel Chemie-Pumpe zu - Pol	cable	Câble	cavo
24	21047300	1	T-Stück D12	hose nozzle	Tubulure fileté	beccocio tubo flessibile
25	50986300	1	PVC-Schlauch transp. 5x1,5 L= 1,600 m	hose	Tuyau	tubo flessibile
26	21054900	1	FW-Pumpe mit Halter	pump	Pompe d'eau propre	pompa
27	20272500	6	Schlauchschele W412-22/9	hose clamp	Collier	fascetta tubo flessibile
28	50680800	1	PVC-Gewebeschlauch Ø13x3 L=40mm	hose	Tuyau	tubo flessibile
29	50680800	1	PVC-Gewebeschlauch Ø13x3 L=?mm	hose	Tuyau	tubo flessibile
30	50680800	1	PVC-Gewebeschlauch Ø13x3 L=?mm	hose	Tuyau	tubo flessibile
31	21061100	1	Aufschraubtülle G1/2" LW13	nozzle	Tubulure fileté	beccuccio
32	21073200	1	6-Kt Mutter G1/2"	hex.nut	Ecrou hexagonal	dado
33	21073600	1	Dichtring	seal	Rondelle d'étanchéité	gzarnizione
34	20000300	1	Scheibe 4,3	washer	Rondelle	rondella
35	20343800	1	Zylinderschraube M 4x8	cylindrical head screw	Vis cylindrique	vite
36	21041700	2	Flasche PA leer 1L	container 1l	bidon 1l	flacone
37	20616000	1	Schutzkappe	protective cap	Capuchon de protection	
38	20970601	1	Schlauch mit Halter	hose	Tuyau	
39	21342000	1	Rastfeder	locking disc	disque de blocage	disco di bloccaggio
40	21341900	1	Rastscheibe	locating disc	Rondelle	rondella
41	20054500	1	Scheibe 10x16x1	washer	Rondelle	rondella

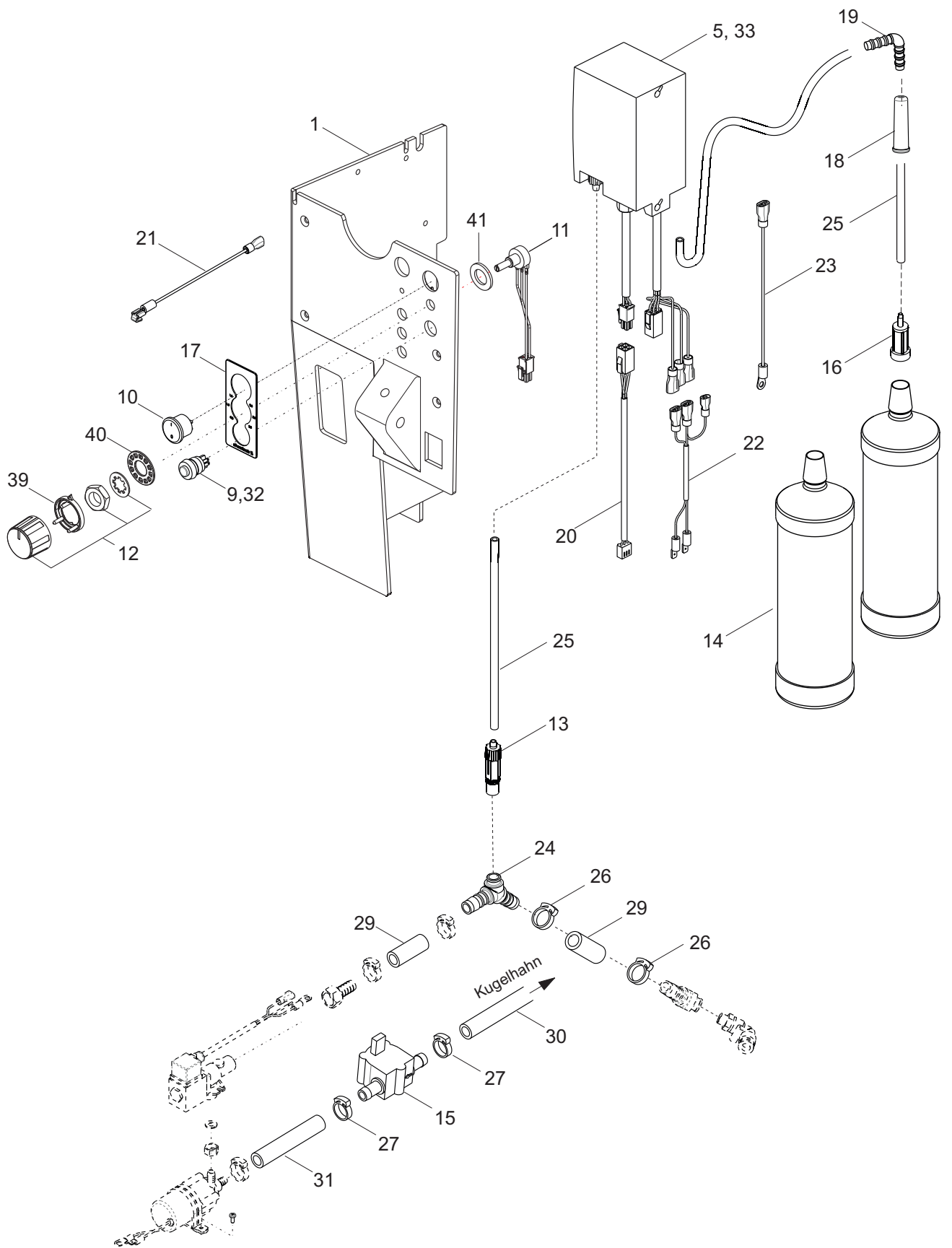

columbus

**RA 66|BM 60
RA 66|BM 60 iL**

Chemiedosierung 66

Pos.	Art. Nr.	Stück	Bezeichnung	Description	Designation	Descrizione
1	21156301	1	Rückwand iL Chemiedosierung	electric box	électrocaisse	elettrocassetta
	21056303	1	Rückwand Chemiedosierung	electric box	électrocaisse	elettrocassetta
5	20970600	1	Chemie-Pumpe C0059-1	pump for chemistry	Pompe pour la chimie	pompa per la chimica
9	20369100	1	Druckknopfschalter	push-button switch	Commutateur	interruttore a pulsanze
10	21044000	1	Wippschalter rund Ein-Aus	switch	Interrupteur	interruttore
11	21168730	1	Potentiom.100KOhm-16 Kabel	potentiometer	Potentiomètre	potenziometro
12	21168830	1	Potentiometer-Knopf	potentiometer button	Bouton potentiomètre	manopola potenziometro
13	20970800	1	Rückschlagventil Chemie	retention valve	valve de retenue	valvola antiritorno
14	21041700	2	Flasche PA leer 1L	flow indicator	débitmètre	flacone
15	20970700	1	Durchlaufmesser	filter	filtre	flussometro
16	20405300	1	FW-Filter	sticker	Autocollant	filtro
17	70108300	1	Aufkleber Chemiedosierung	grommet	Buchon pour cable	etichetta
18	21046400	2	Knickschutztülle D9	hose nozzle	Tubulure fileté	passacavo
19	21041800	1	Verbindungsstutzen	cabl	Câble	beccocio tubo flessibile
20	21041400	1	Kabel Pumpe-Durchlaufm.	cabl	Câble	cavo
21	21069800	1	Kabel zu Schlüsselschalter	cabl	Câble	cavo
22	21069900	1	Kabel Chemie-Pumpe	cabl	Câble	cavo
23	21070000	1	Kabel Chemie-Pumpe zu -Pol	cabl	Câble	cavo
24	20681501	1	Y-Schlauchstutzen D12	hose nozzle	Tubulure fileté	beccocio tubo
25	50986300	1,100 m	PVC-Schlauch transp. 5x1,5	hose	Tuyau	tubo flessibile
26	20596500	2	Schlauchklemme D17-18,5	hose clamp	Collier	fascetta tubo flessibile
27	20272500	2	Schlauchschelle W412-22/9	hose clamp	Collier	fascetta tubo flessibile
28	20681502	1	Y-Schlauchstutzen D12	hose nozzle	Tubulure fileté	raccordo aY
29	50680800	0,060 m	PVC-Gewebes Schlauch Ø13x3	hose	Tuyau	tubo flessibile
30	50680800	0,230 m	PVC-Gewebes Schlauch Ø13x3	hose	Tuyau	tubo flessibile
31	50680800	0,480 mm	PVC-Gewebes Schlauch Ø13x3	hose	Tuyau	tubo flessibile
32	20616000	1	Schutzkappe	protective cap	Capuchon de protection	
33	20970601	1	Schlauch mit Halter	hose	Tuyau	
39	21342000	1	Rastfeder	locking disc	disque de blocage	disco di bloccaggio
40	21341900	1	Rastscheibe	locating disc	Rondelle	rondella
41	20054500	1	Scheibe 10x16x1	washer	Rondelle	rondella

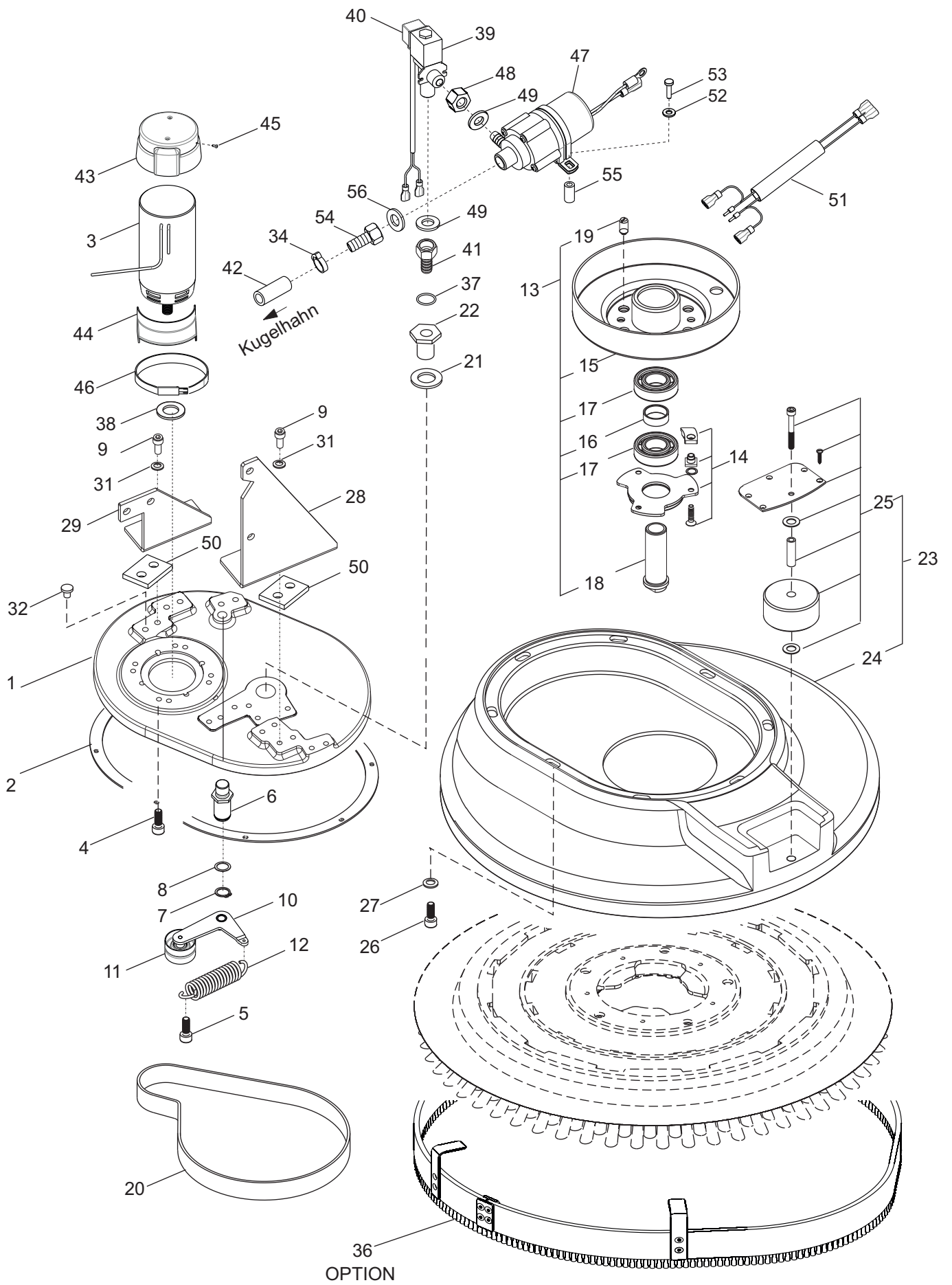

RA 55|BM 60
 RA 55|BM 60 iL

Bürstantrieb 55

Pos.	Art. Nr.	Stück	Bezeichnung	Description	Designation	Descrizione
	21066431	1	Bürstantrieb kpl. 55	Brush drive cpl. 55	Moteur brosse 55	Motore spazzola 55
1	20250300	1	Getriebegehäuse	gear cover	Carcasse	copertura spazzola
2	20552300	1	Dichtung f.Getriebedeckel	gasket f. gear cover	Joint	guarnizione copertura
3	20402101 20987100	1	Motor 24V 500W Kohlebürste	motor 24V 500W carbon brush	Moteur 24V 500W balai en charbon	motore 24V 500W carboncino
4	20279200	4	Zylinderschraube M 6x16	cylindrical head screw	Vis cylindrique M6x16	vite
5	20278900	1	Zylinderschr.DUO-T.EM 8x20	cylindrical head screw	Vis cylindrique EM8x20	vite
6	20141301	1	Bolzen	bolt	Boulon	bullone
7	20142400	1	Sicherungsring I 15x1 DIN471	circlip	Rondelle de sécurité	anello d'arresto
8	20006100	1	Kugell.A.Sch.15,8x21,5x0,2	washer	Rondelle	rondella
9	20408200	6	Zylinderschr.DUO-T.EM 8x25	cylindrical head screw	Vis cylindrique EM8x25	vite
10	20356630	1	Riemenspanner BG	belt tightener cpl.	Tendeur courroie	tendicinghia
11	20571830	1	Umlenkrolle kpl.	idler pulley cpl.	Rouleau de renvoi	puleggia di rinvio
12	20374600	1	Zugfeder Z-172I	extension spring	Ressort	molla di trazione
13	20418532	1	Riemenscheibe kpl.	Drive Pulley; assy	Poulie pour courroie	puleggia transm. a cinghia
14	20609231	1	Segmentscheibe kpl.	Segmental plate	Meule segmentée	flangia
15	20609530	1	Riemenscheibe	Drive Pulley	Poulie pour courroie	puleggia transm. a cinghia
16	20565100	1	Distanzring Riemenscheibe	distance ring	bague d'espacement	distanziale
17	20140700	2	Rillenkugellager 6205 2RS	bearing 6205 2RS	Roulement à billes	cuscinetto
18	20371300	1	Welle	shaft	Axe	albero
19	20220900	3	Druckstück federnd M10x21	pressure piece	groupille de pression	pezzo di pressione elastico
20	20270300	1	Poly-V-Riemen J14/886	belt	Courroie poly V	cinghia
21	20373400	1	Scheibe 21,0x37,0x3,0	washer	Rondelle 21x37x3	rondella
22	20372500	1	Mutter für Riemenscheibe	hex.nut	Ecrou pour poulie	dado puleggia
23	20427331	1	Abdeckung Ø520 kpl.	Cover D530 assy	Couvercle de brosse	copertura compl.
24	20251302	1	Abdeckung Ø520	cover Ø530	Couvercle de brosse	copertura
25	20555630	1	Abweisrolle kpl.	Protecting caster assy	Roulette de protection	ruota di protezione
26	20036200	8	Zylinderschraube EM5x20	cap screw EM5x20	Vis cylindrique EM5x20	vite
27	20112900	8	Scheibe 5,3x15,0x1,0	washer 5,3	Rondelle 5,3x15x1	rondella
28	21066500	1	Bürstwinkel rechts	angle, right	Angle droite	angolo
29	21066600	1	Bürstwinkel links	angle, left	Angle gauche	angolo
31	20005500	3	Sicherungsscheibe SMZ 8	lock washer	Rondelle de sécurité	anello d'arresto
32	20359500	12	Abdeckkappe	cover	Capot	tappo
34	20596500	1	Schlauchklemme D17-18,5	hose clamp	Collier	fascetta tubo flessibile
36	21042032	1	Spritzschutz 55	splash guard	Pare-éclaboussures	paraspruzzi
37	21063200	1	O-Ring 10x1	O-ring	joint ronde	anello di tenuta
38	21070500	1	Dichtung für Motor	seal	Joint	guarnizione
39	21055030	1	Magnetventil	magnetic valve	Electrovalve	elettrovalvola
40	21055011	1	Gerätestecker f. Magnetventil	appliance plug	Prise	spina elettrovalvola
41	21061101	1	Aufschraubschlauchtülle LW13-Ø13,7	nozzle	Tubulure filetée	beccuccio
42	50680800	0,75 m	PVC-Gewebeschlauch Ø13x3	hose	Tuyau	tubo flessibile
43	21073300	1	Motorabdeckung oben	motor cover	Couvercle de brosse	copertura
44	21073400	1	Motorabdeckung unten	motor cover	Couvercle de brosse	copertura
45	20040900	3	Blechschr.Li 3,5x9,5	screw	Vis	vite
46	21075300	1	Befestigungsschelle	clamp	Collier	morsetto
47	21054930	1	FW-Pumpe mit Halter	fresh water pump	Pompe eau propre	pompa

Bürstantrieb 55

Pos.	Art. Nr.	Stück	Bezeichnung	Description	Designation	Descrizione
48	21073200	1	6-Kt Mutter G1/2"	hex.nut	Ecrou hexagonal	dado
49	21073600	2	Dichtring	sealing ring	Rondelle d'étanchéité	anello di tenuta
50	20786300	4	Unterlage		Plaque	piastra
51	21070200	1	Kabel	cable	Câble	cavo
52	20000300	1	Scheibe 4,3	washer	Rondelle	rondella
53	20083800	1	Zylinderschraube M 4x35 VA	cylindrical head screw	Vis cylindrique	vite
54	21246700	1	Aufschraubtülle G3/8" LW13	nozzle	Tubulure fileté	beccuccio
55	20442403	1	Hülse L=28 f.Gummirolle	sleeve	Douille	boccola
56	20107300	1	Dichtung	sealing ring	Rondelle d'étanchéité	anello di tenuta

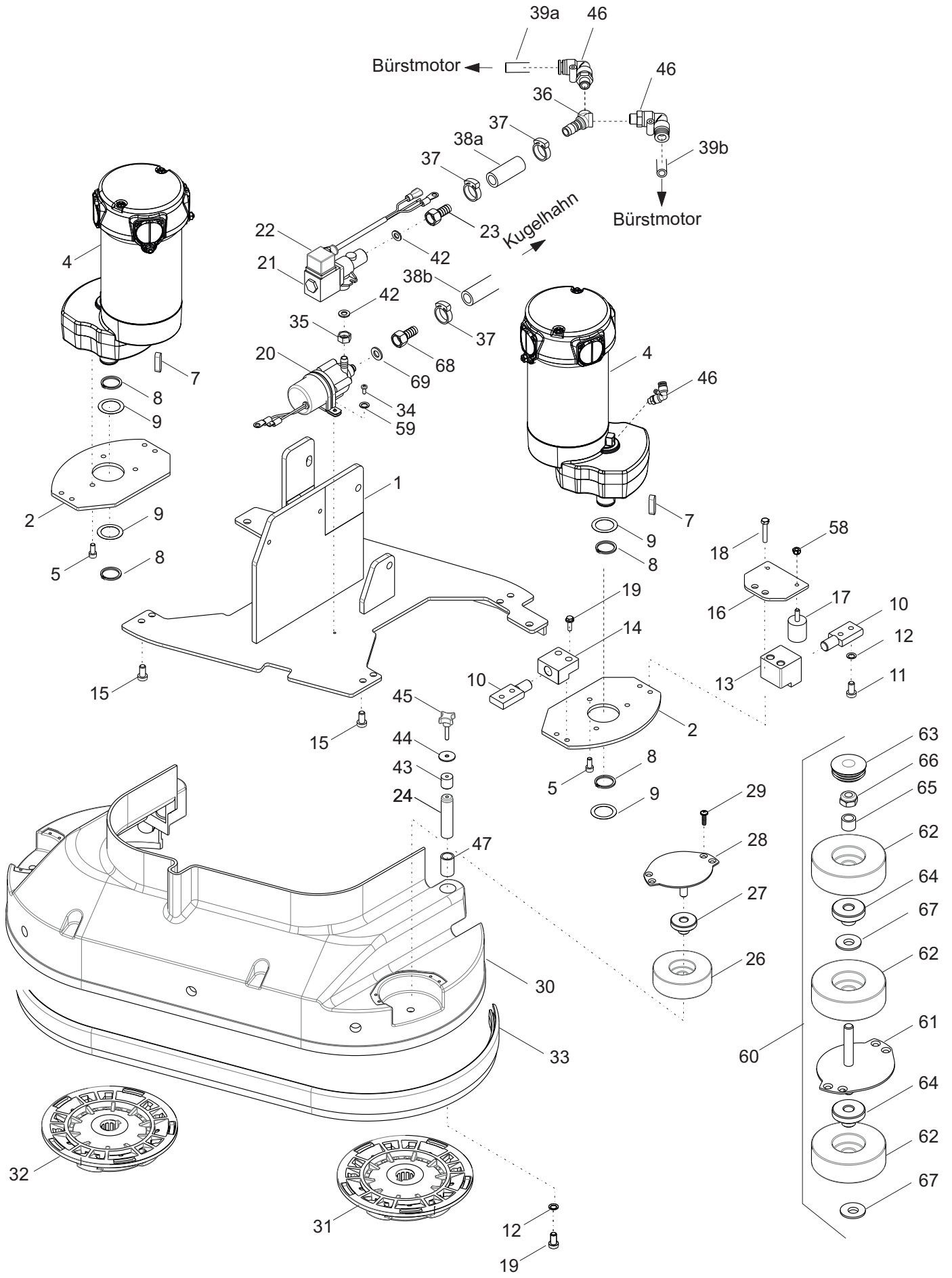

columbus

**RA 66|BM 60
RA 66|BM 60 iL**

Bürstantrieb 66

Pos.	Art. Nr.	Stück	Bezeichnung	Description	Designation	Descrizione
	21050331	1	Bürstantrieb kpl. 66	Brush drive cpl. 66	Moteur brosse 66	Motore spazzola 66 BM
1	21050301	1	Bürstplatte mittig	supported slab for brush, central	plaque de support centrale de la brosse	piastra centrale
2	21050400	2	Bürstplatte seitlich	supported slab for brush, latéral	Plaque de support latérale de la brosse	piastra laterale
4	21374200	2	Bürstmotor 250W 24V	motor 24V 250W	Moteur de brosse 24V 250W	motore 24V 250W
	21051210		Kohlebürsten-Set	carbon brush	balai en charbon	carboncino
5	20567500	6	Zylinderschraube M 6x14	cylindrical head screw	Vis cylindrique	vite
7	21057600	2	Passfeder 8x7x30 VA	featherkey	Ressort d'ajustage	linguetta di aggiustamento
8	21057700	4	Sicherungsring AS 25x2	circlip	Rondelle de sécurité	anello d'arresto
9	21045700	4	Pass-Scheibe 25x35x0,2	shim ring	Rondelle d'ajustage	rondella di aggiustamento
10	21050800	4	Gelenk	articulation	Articulation	giunto
11	20152000	4	Zylinderschraube M 8x16 Zn	cylindrical head screw	Vis cylindrique	vite
12	20005500	8	Sicherungsscheibe SMZ 8	lock washer	Rondelle de securité	rondella di sicurezza
13	21050702	2	Gelenk abgesetzt	stepped articulation	articulation étagée	giunto
14	21050703	2	Gelenk abgesetzt kurz	articulation short, stepped	articulation courte,étagée	giunto
15	20195300	4	Verbusschraube M8x20	hex.screw	Vis à tête hex.	vite
16	21050901	2	Gelenkplatte	plate	plaque	piastra
17	21054800	4	Gummi-Metall-Puffer hart	bumper	Tampon	tampone
18	20191700	4	6-Kt Schraube M 8x45	hex.screw	Vis à tête hex.	vite
19	20195300	4	Verbusschraube M 8x20	hex.screw	Vis à tête hex.	vite
20	21054930	1	FW-Pumpe mit Halter	fresh water pump	Pompe eau propre	Pompa
21	21055030	1	Magnetventil	magnetic valve	Electrovalve	elettrovalvola
22	21055012	1	Gerätestecker GSA	appliance plug	Prise	spina elettrovalvola
23	21061100	1	Aufschraubtülle G1/2" LW13	nozzle	Tubulure filetée	beccuccio
24	21064500	2	Führungsbolzen	bolt	Boulon	bullone
26	21053700	2	Abweisrolle D80	protecting caster	Roulette de protection	ruota di protezione
27	21054600	2	Führungsstopfen	stopper	Bouchon	tappo
28	21057800	2	Platte Abweisrolle	plate	Plaque	piastra
29	20681900	8	Schraube KB 50x16 schw.	screw	Vis	vite
30	21051000	1	Bürstabdeckung	brush cover	Couverture de brosse	copertura
30a	21051031	1	Bürstabdeckung kpl.	brush cover compl.	Couverture compl.	copertura int.
31	21050500	1	Bürsttaufnahme rechtsdrehend, grau	Brush unit, clockwise, grey	Unité de brosse, tournant vers la droite, gris	
32	21050501	1	Bürsttaufnahme linksdrehend, schwarz	Brush unit, counterclockwise, black	Unité de brosse, tournant vers la gauche, noir	
33	21051100	1	Halteprofil mit Bürstenstreifen	fixation profile for brush strips	profile de fixation pour bande de protection balai	
34	20001200	1	Linsenschraube M4x10	lens screw	Vis à tête bombée	vite
35	21073200	1	6-Kt Mutter G1/2"	hex.nut	Ecrou hexagonal	dado
36	20681502	1	Y-Schlauchstutzen 2x1/8"	hose nozzle	Tubulure filetée	raccordo aY
37	20272500	3	Schlauchschelle W4 12-22/9	hose clamp	collier	fascetta tubo flessibile
38a	50680800	0,110m	PVC-Gewebes Schlauch Ø13x3	hose	Tuyau	tubo flessibile

Bürstantrieb 66

Pos.	Art. Nr.	Stück	Bezeichnung	Description	Designation	Descrizione
38b	50680800	0,750m	PVC-Gewebes Schlauch Ø13x3	hose	Tuyau	tubo flessibile
39a	51074700	1	PU-Schlauch Ø8 0,280m	hose	Tuyau	tubo flessibile
396	51074700	1	PU-Schlauch Ø8 0,230m	hose	Tuyau	tubo flessibile
42	21073600	2	Dichtring	sealing ring	Rondelle d'étanchéité	anello di tenuta
43	21074500	1	Gewindebuchse M6	bush	Bouchon	boccola
44	20191100	1	Scheibe 6,5x28x2,5	washer	Rondelle	rondella
45	21074400	1	Kreuzgriffschraube M6x35	star wheel screw	Vis avec poignée étoile	vite grip a stella
46	21074600	4	Winkelstutzen R1/8	hose nozzle	Tubulure filetée	boccola angolare
47	50203100	0,040m	Schlauch 20x3	hose	Tuyau	tubo flessibile
58	20070000	4	6-Kantmutter M 6 stopp	hex.nut	Ecrou hexagonal	dado essag.
59	20060000	1	Sicherungsscheibe SMZ 4	lock washer	Rondelle de sécurité	rondella di sicurezza
60	21057930	2	Abweisrolle hoch (optional)	protecting caster high assy	Roulette de protection haute (Option)	ruota di protezione
61	21057900	1	Platte Abweisrolle hoch	plate	Plaque por roulette	piastra
62	21053700	3	Abweisrolle D80	protecting caster	Roulette de protection	ruota di protezione
63	20768900	1	Stopfen schwarz	stopper black	Bouchon	tappo
64	21054600	2	Führungsstopfen	stopper	Bouchon	tappo
65	21048100	1	Hülse 10,5x15x12	sleeve	Douille	boccola
66	20682400	1	6-Kantmutter M10 stopp	hex.nut	Ecrou hexagonal	dado essag.
67	20054500	2	Scheibe 10,5	washer	Rondelle	rondella
68	21246700	1	Aufschraubtülle G3/8" LW13	nozzle	Tubulure filetée	beccuccio
69	20107300	1	Dichtung	sealing ring	Rondelle d'étanchéité	anello di tenuta

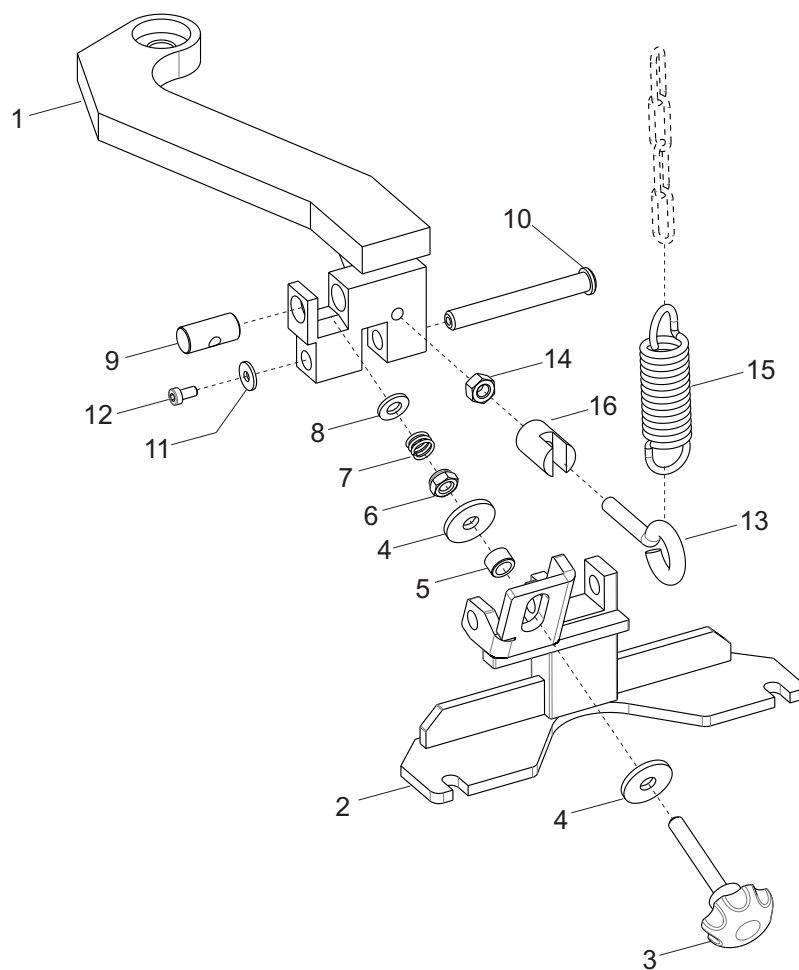

columbus

RA 55|BM 60
 RA 66|BM 60
 RA 55|BM 60 iL
 RA 66|BM 60 iL

Aufhängung Gerätedüse

Pos.	Art. Nr.	Stück	Bezeichnung	Description	Designation	Descrizione
	21051531		Aufhängung Gerätedüse kpl.	Attachement kpl.	Fixation buse d'aspiration	Fissaggio bocchetta
1	21051500	1	Arm Gerätedüse	bracket	Bras buse d'aspiration	braccio
2	21061700	1	Halter Gerätedüse	support	Reteneur buse d'aspiration	supporto
3	20585500	1	Sterngriffschraube M8x55	star wheel screw	Vis avec poignée étoile	vite grip a stella
4	20277800	2	Scheibe 9,0x28,0x3	washer	Rondelle	rondella
5	20619900	1	Distanzbuchse D12/8 x 7,5	bush	Buchon d'espacement	boccola
6	20280500	1	6-Kantmutter M 8 stopp	hex.nut	Ecrou hexagonal	dado essag.
7	20856100	1	Druckfeder VD-207KA VA	compression spring	Ressort de compression	molla di compressione
8	20067600	1	Scheibe 8,4x17,0x2,0	washer	Rondelle	rondella
9	20801300	1	Gelenk Düsenneigung	articulation	Articulation	giunto
10	21077600	1	Bolzen Gerätedüse	bolt	Boulon	bullone
11	20112900	1	Scheibe 5,3x15,0x1,0	washer	Rondelle	rondella
12	20730900	1	Zylinderschraube M 5x10	cylindrical head screw	Vis cylindrique	vite
13	20801500	1	Ringschraube M8x40	ring screw	vis à anneau de levage	vite occhiello
14	20000500	1	6-Kantmutter M8	hex.nut	Ecrou hexagonal	dado essag.
15	20568500	1	Zugfeder Z-177	tension spring	Ressort de traction	molla di tensione
16	21078800	1	Hülse	sleeve	douille	boccola

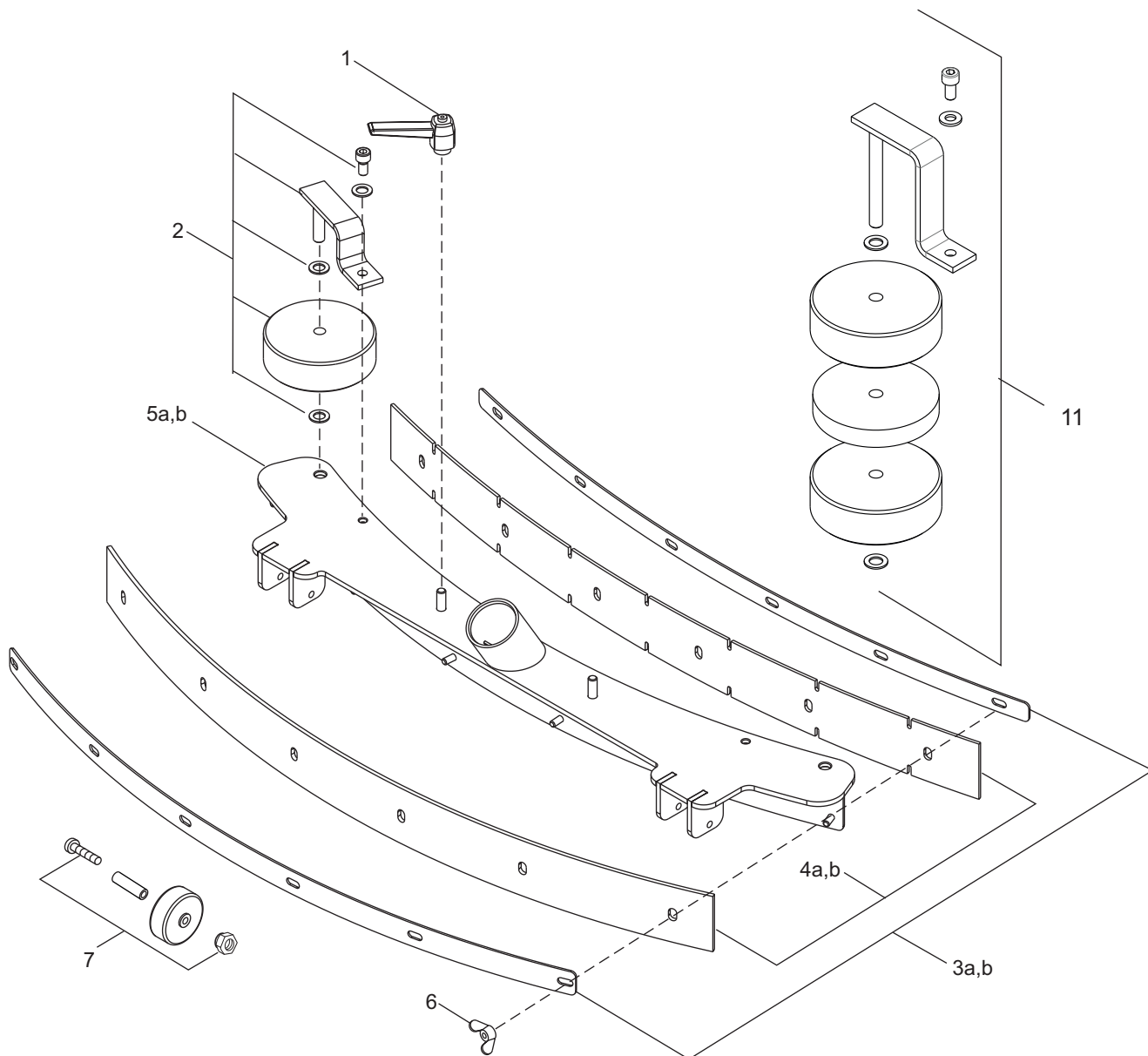

Gerätedüse

Pos.	Art. Nr.	Stück	Bezeichnung	Description	Designation	Descrizione
	20623634		Gerätedüse kpl. 55	squeegee tool cpl. 55	Buse d'aspiration 55	bocchetta compl. 55
	20623733		Gerätedüse kpl.66	squeegee tool cpl. 66	Buse d'aspiration 66	bocchetta compl. 66
1	20783230	1	Klemmhebel Satz (2 Stück)	clamping lever set (2 pieces)	Levier pour fixation (set)	set lavetta di fissaggio
2	20622830	2	Abweisrolle niedrig kpl.	low protecting caster assy	Roulette de protection bas	ruota di protezione
3a	20621230	1	Klemmleisten Satz 55	Fixation (set) 55	Fixation (set) 55	set piattina bloccagomma 55
3b	20620230	1	Klemmleisten Satz 66	Fixation (set) 66	Fixation (set) 66	set piattina bloccagomma 66
4a	20620531	1	Sauglippen Satz 55	Listels set 55	Listels set 55	set lamelle 55
4b	20620031	1	Sauglippen Satz 66	Listels set 66	Listels set 66	set lamelle 66
5a	20620402	1	Gerätedüse 55 D50 schräg	squeegee tool 55	Buse d'aspiration 55	bocchetta 55
5b	20618903	1	Gerätedüse 66 D50 schräg	squeegee tool 66	Buse d'aspiration 66	bocchetta 66
6	20623130	1	Flügelmutter Satz (12 Stück)	nut set (12 pieces)	Ecrou (set-12 pieces)	set dado a farfalla
7	20442433	2	Gummirolle	rubber rol	Roulette	rotella
11	20621430	2	Abweisrolle 66 hoch kpl. (optional)	high protecting caster assy	Roulette de protection haute (Option)	ruota di protezione

columbus

**RA 55|BM 60
RA 66|BM 60
RA 55|BM 60 iL
RA 66|BM 60 iL**

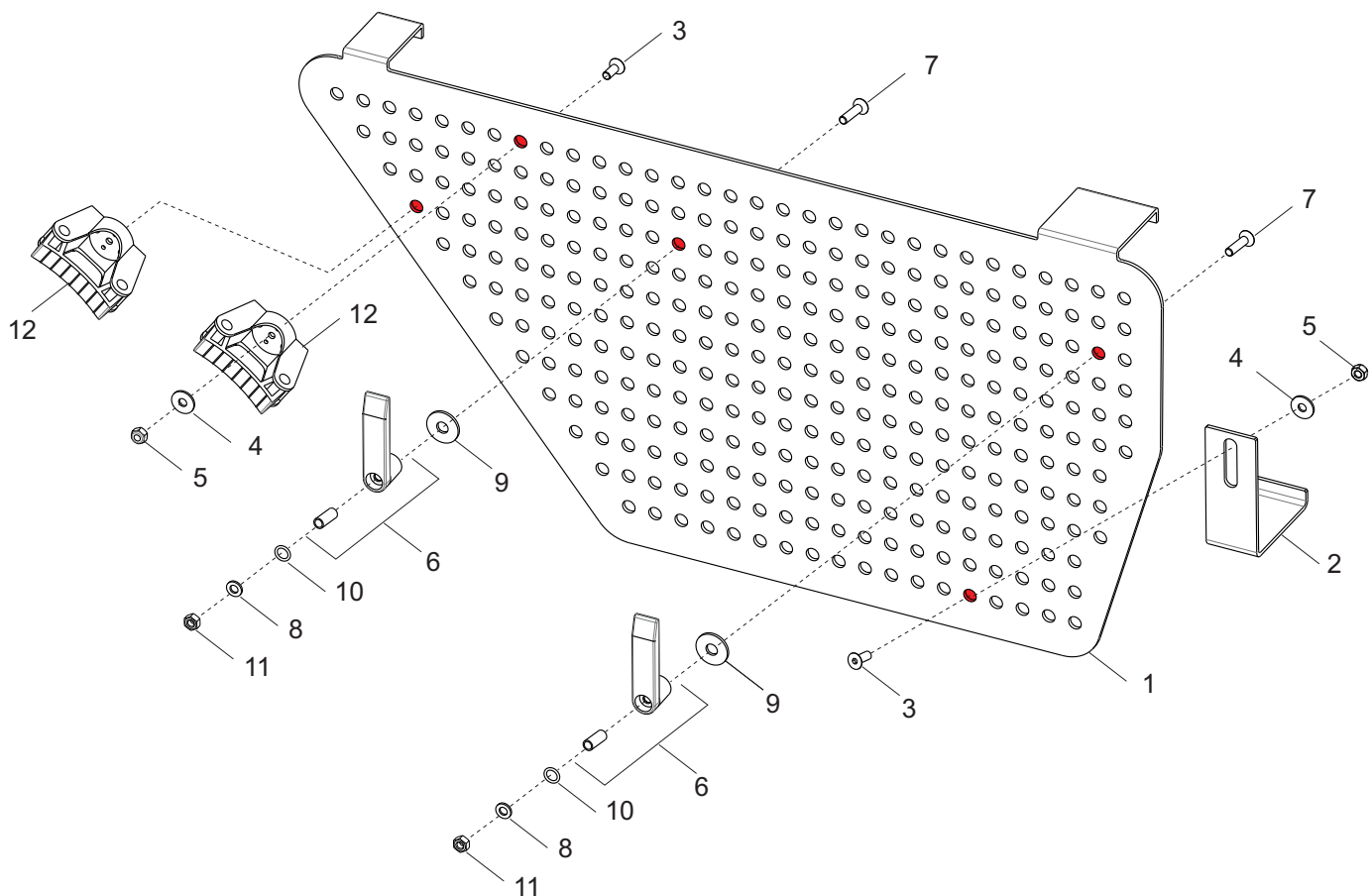

Tool board (optional)

Pos.	Art. Nr.	Stück	Bezeichnung	Description	Designation	Descrizione
	21053530	1	Tool-board optional	tool-board optional	tool-board optional	tool-board optional
1	21053500	1	Tool-board	tool-board	tool-board	tool-board
2	21053600	1	Halter tool-board	support	Support	supporto
3	20220000	3	Senkschraube M6x16 10.9	countersunk	Ecrou M6	vite
4	20113000	3	Scheibe 6,4x17,6x1,5	washer	Rondelle	rondella
5	20070000	3	6-Kantmutter M6 stopp	hex.nut	Ecrou M6	dado essag.
6	20319600	2	Kabelhaken	cable hook	Crochet	gancio
7	21076400	2	Senkschraube M6x30	countersunk	Ecrou M6	vite
8	20000700	2	Scheibe 6,4x12,0x1,5	washer	Rondelle	rondella
9	20113000	2	Scheibe 6,4x17,6x1,5 VA	washer	Rondelle	rondella
10	20930900	2	O-Ring 8,5x1,5	O-ring	Joint rond	guarnizione
11	20070000	2	6-Kantmutter M6 STOPP VA	hex.nut	Ecrou M6	dado essag.
12	20557700	2	Toolflex-Halterung	Tool holder (mop rack)	Encoche à cliquet bloquant	supporto

columbus

**RA 55|BM 60
RA 66|BM 60
RA 55|BM 60 iL
RA 66|BM 60 iL**

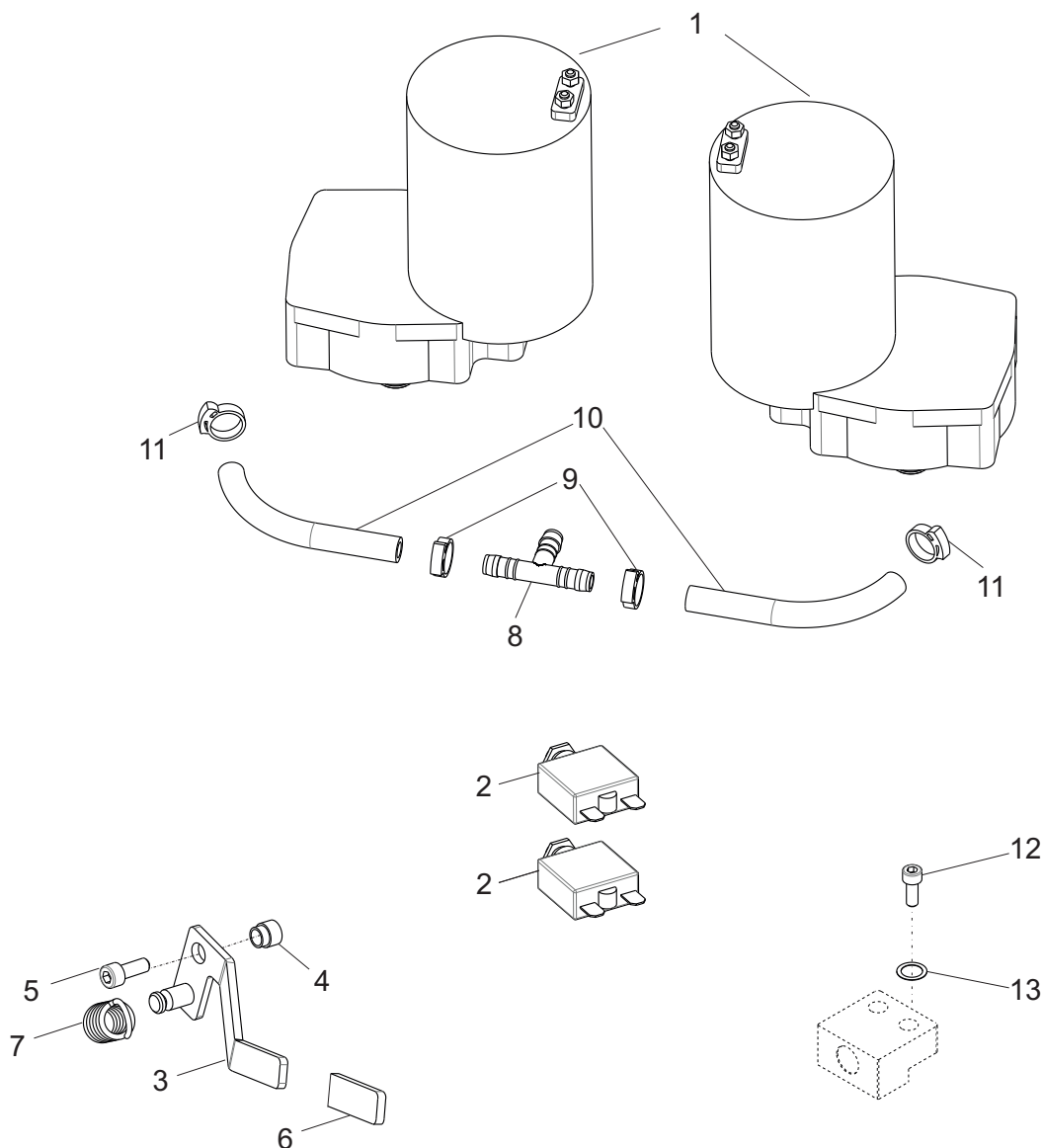

Kit Leistungssteigerung (optional)

Pos.	Art. Nr.	Stück	Bezeichnung	Description	Designation	Descrizione
1	21387001	2	Bürstenmotor 550W 24V	motor 24V 550W	Moteur de brosse 24V 550W	motore 24V 550W
2	21077800	2	Überstromschutzsch.25A (RA 66 BM 60)	fuse 25A	Fusible 25A	fusibile
3	21052300	1	Hebel Bürstdruck	lever	Levier	leva
4	21070700	1	Buchse	bush	Brousse	boccola
5	20152000	2	Zylinderschraube M 8x16	cylindrical head screw	Vis cylindrique	vite
6	20188001	1	Flachkappe 3x15x80	lever sheathing	Revêtement de protection du levier	ricoprimento leva
7	21058000	1	Zugfeder RZ 174 I rostfrei	extension spring	Ressort de traction	molla di trazione
8	31047300	1	T-Stück 12	hose nozzle	Tubulure fileté	beccocio tubo flessibile
9	20596500	2	Schlauchklemme D17-18,5	hose clamp	Collier	fascetta tubo flessibile
10	50660300	2 x 0,25m	PVC-Gewebeschauch D10x3	hose	Tuyau	tubo flessibile
11	20628400	2	Schlauchklemme D15-17,2	hose clamp	Collier	fascetta tubo flessibile
12	20076700	4	Zylinderschraube M 8x20 VA	cylindrical head screw	Vis cylindrique	vite
13	20005500	4	Sicherungsscheibe SMZ 8 Zn	lock washer	Rondelle de sécurité	anello d'arresto

Änderungen im Zuge technischer Verbesserungen sind vorbehalten !
We reserve the right to effect modifications within the framework of technical progress !
Sous réserve de modification dans le cadre des développements techniques !
Essendo la nostra un'impresa a carattere innovativo, ci riserviamo la possibilità di apportare modifiche tecniche !

G. Staehle GmbH u. Co. KG
columbus Reinigungsmaschinen
Mercedesstr. 15
D - 70372 Stuttgart
Telefon +49(0)711 / 9544-950
Telefax +49(0)711 / 9544-941

info@columbus-clean.com
www.columbus-clean.com

70110000

columbus