

E 500ls

**Ersatzteilliste
Einscheibenmaschine**

**Spare parts list
Single brush machine**

**Catalogue des pièces de rechange
Monobrosse**

**Elenco pezzi di ricambio
Monospazzole**

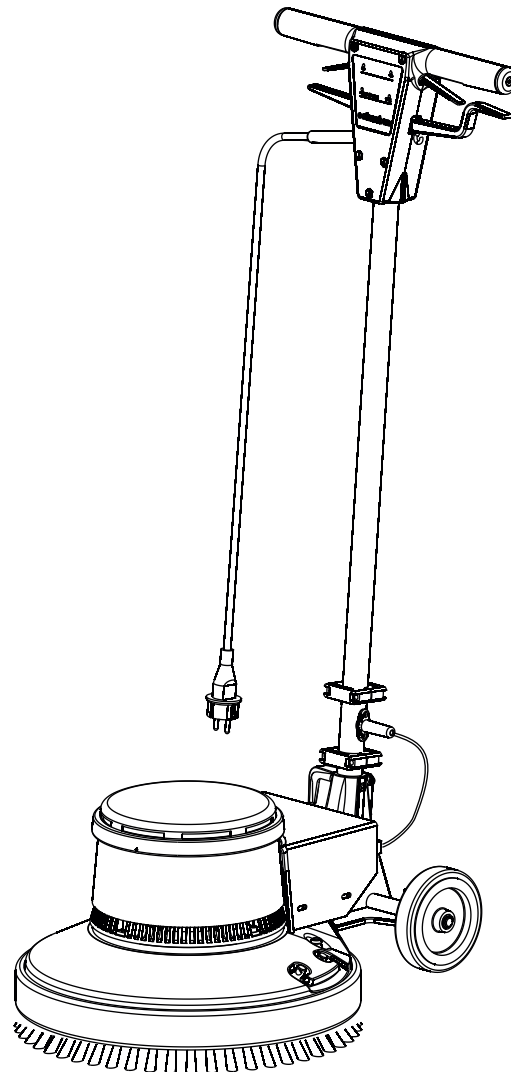

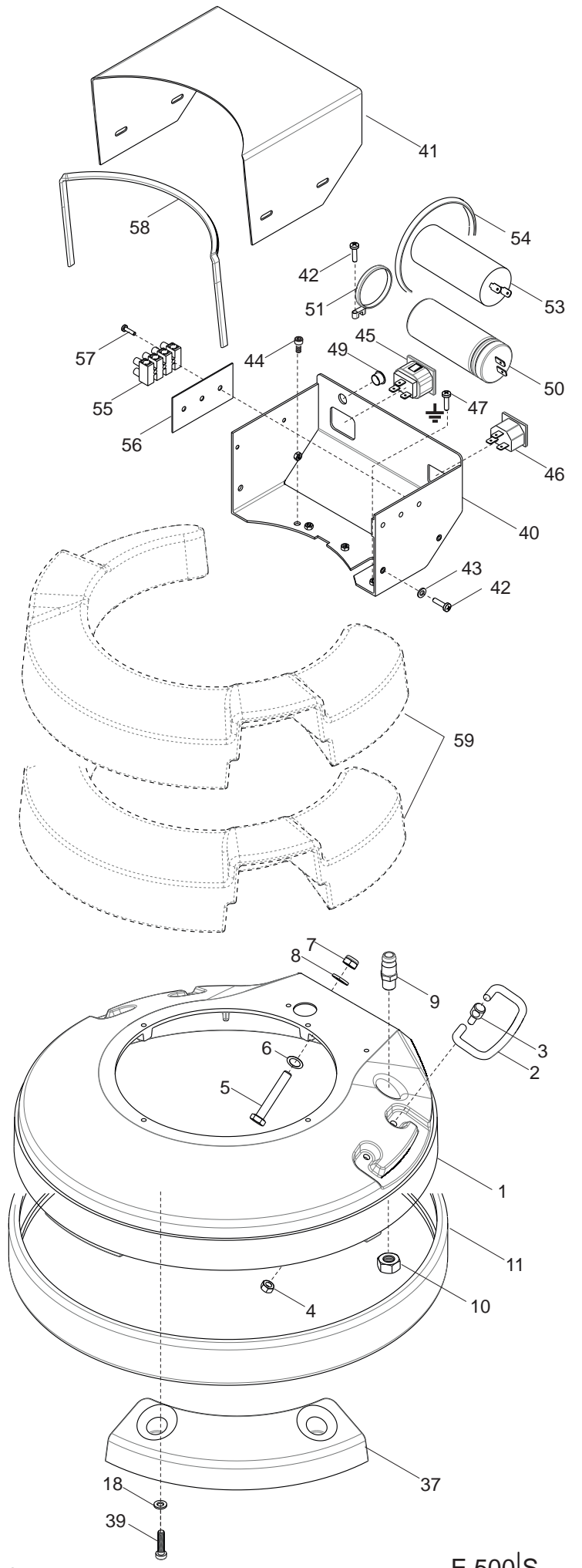
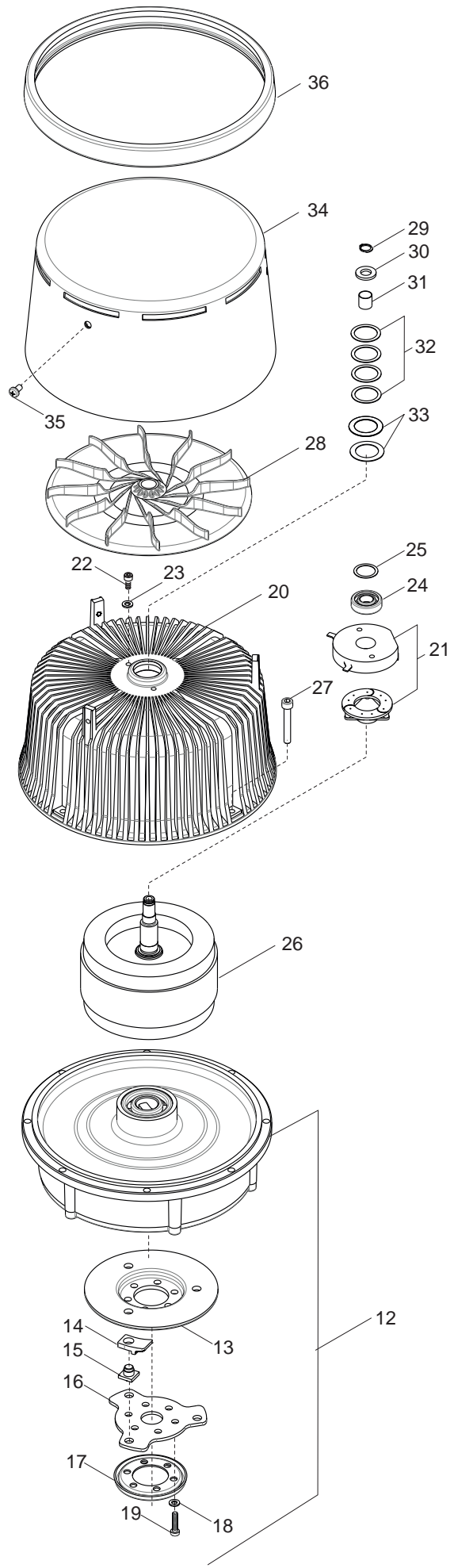

Maschinenkörper E 500 | S

Pos.	Art.Nr.	Stück	Bezeichnung	Description	Designation	Descrizione
1	20412601	1	Blockergehäuse E500	housing E500	Chassis pour machine E500	piatto macchina E500
2	20026500	2	Tragegriff	carrying handle	Poignée	maniglia trasporto
3	20026400	4	Bolzen für Tragegriff	bolt for handle	Boulon	bullone
4	20070000	4	6-Kantmutter M6 STOPP	hex.nut M6 STOPP	Ecrou M6 STOPP	dado esagonale M6 STOPP
5	20279900	2	Gewindeschneidschr. M8x50	hex.screw M8x50	Vis 6-pans M8x50	vite esagonale M8x50
6	20005500	2	Sicherungsscheibe SMZ 8	lock washer SMZ 8	Rondelle SMZ 8	rondella di bloccaggio SMZ 8
7	20280500	2	6-Kantmutter M8 STOPP	hex.nut	Ecrou	dado esagonale
8	20067600	2	Scheibe 8,4x17x2	washer	Rondelle	rondella
9	20023000	1	Schlauchtülle	hose sleeve	Douille	portatubo
10	20009300	1	6-Kantmutter M12x1	hex.nut M12x1	Ecrou M12x1	dado esagonale M12x1
11	20031300	1	Stoßring E500	bumper E500	Anneau de protection E500	paracolpi sottile E500
12	20530341	1	Planetengetriebe 3PL 1:10 mit Bürstaufnahme	planetary gear 3PL 1:10	Engrenage planétaire	ingranaggio satellitare
	20544331	1	Bürstaufnahme	brush holder	Support brosse	supporto spazzola
13	20057000	1	Zwischenscheibe	intermediate ring	Rondelle interméd.	distanziale
14	20062000	3	Anschlagstück	rubber piece	Arrêt	scodellino
15	20057200	3	Mitnehmerbolzen	catch bolt	Boulon	perno
16	20574000	1	Segmentscheibe D100/D20	segment ring D100/D20	Anneau	flangia
17	20058900	1	Zentrierring D67/D3x1,5	centring ring D67/D3x1,5	Anneau de centrage	anello di centraggio
18	20008000	8	Sicherungsscheibe SMZ6	lock washer SMZ6	Rondelle SMZ6	rondella di bloccaggio SMZ6
19	20567500	6	Zylinderschraube M6x14	cap screw M6x14	Vis cylindrique M6x14	vite cilindrica M6x14
20	20444431	1	Motorgehäuse mit Stator P80	motorhousing with stator P80	Boîte moteur avec stator P80	coppa motore con statore P80
21	20037600	1	Fliehkraftschalter	centrifugal switch	Interrupteur centrifuge	disgiuntore
22	20010500	2	Zylinderschraube M4x16	cap screw M4x16	Vis cylindrique M4x16	vite cilindrica M4x16
23	20060000	2	Sicherungsscheibe SMZ4	lock washer SMZ4	Rondelle SMZ4	rondella di bloccaggio SMZ4
24	20006000	1	Rillenkugellager 6001 2RS	bearing 6001 2RS	Roulement 6001 2RS	cuscinetto 6001 2RS
25	20045200	1	Kugellager Ausgleichscheibe	washer	Rondelle	rondella
26	20444831	1	Rotor P80	rotor P80	Rotor P80	rotore P80
27	20278800	4	Zylinderschraube DUO-T.EM5x35	cap screw DUO-T.EM5x35	Vis cylindrique EM5x35	vite cilindrica EM5x35
28	20413501	1	Kühlflügel	cooling fan	Ventilateur	ventola di raffreddamento
29	20029700	1	Sicherungsring A 10x1	safety ring A 10x1	Circlips A 10x1	anello di protezione A 10x1
30	20054500	1	Scheibe 10,5 DIN433	washer	Rondelle	rondella
31	20413701	1	Toleranzring BN12x12	ring BN12x12	Anneau BN12x12	anello di tolleranza BN12x12
32	21027700	4	Kugellager-Ausgleichscheibe	washer	rondella	Rondelle
33	20033900	2	Passscheibe 12x16x0,3 DIN988	locating disc	Rondelle	rondella
34	20413206	1	Schutzhaube lang, chrom	cover short	Capot	copertura cromata
35	20006500	3	Linsenschraube M5x10	screw M5x10	Vis M5x10	vite M5x10
36	20056400	1	Schutzring	safety ring	anello paracolpi	Anneau de protection
37	20412700	1	Gegengewicht	counterweight	Contre poids	contrappeso
	20033500		Gegengewicht, schwer			

Maschinenkörper E 500 | S

Pos.	Art.Nr.	Stück	Bezeichnung	Description	Designation	Descrizione
39	20035900	2	Zylinderschraube DUO-T. EM6x25	cap screw DUO-T.M6x25	Vis cylindrique M6x25	vite cilindrica M6x25
40	20413008	1	Schaltkasten Unterteil, blau	switch box lower part, blue	Boîtier partie supérieur	cassetta interruttori inferiore, blu
41	20412911	1	Schaltkasten Oberteil, blau	switch box upper part, blue	Boîtier partie inférieur, bleu	cassetta interruttori superiore, blu
42	20010800	5	Linsenschraube M4x8	screw M4x8	Vis M4x8	vite testa ovale M4x8
43	20000300	4	Scheibe 4,3x9,0x0,7	washer 4,3x9,0x0,7	Rondelle 4,3	rondella 4,3
44	20278200	2	Zylinderschraube DUO-T. CM5x16	screw DUO-T. CM5x16	Vis CM5x16	vite CM5x16
45	21454600	1	Gerätesteckdose 10A	socket 10A	Prise femelle 10A	presa 10 A
46	20530100	1	Gerätestecker	plug	Prise mâle	spina
47	20159300	1	Linsenschraube M4x6	screw M4x6	Vis M4x6	vite M4x6
49	20369600	1	Stopfen GPN300/F7 D10,5	closure GPN300/F7 D10,5	Bouchon	tappo
50	20144800	1	Anlaßkondensator 150µF	starting condenser 150 µF	Condensateur de démarrage 150µF	condensatore di spunto 150 µF
51	20161300	1	Kabelbinder TY 26 M	cable strip	Attache rapide	strip cavo
53	20088500	1	Betriebskondensator 30µF	capacitor 30 µF	Condensateur de travail 30µF	condensatore 30 µF
54	20135800	1	Kabelbinder TY 35 M	cable strip	Attache rapide	strip cavo
55	20409300	1	Klemmleiste 4-pol	terminal 4 poles	Domino à 4-pôles	morsettiera 4 poli
56	20544200	1	Isolierfolie	terminal insulation	Isolation	lamina isolante
57	20018400	2	Linsenschraube M3x16	screw M3x16	Vis M3x16	vite testa ovale M3x16
58	20413601	1	Kantenschutz für Schaltkasten	gasket	Protection	profilo di protezione
59	20932330	1	Zusatzgewicht 20kg (optional)	additional weight 20kg (option)	Poids supplémentaire 20kg (en option)	peso aggiuntivo 20kg (opzionale)

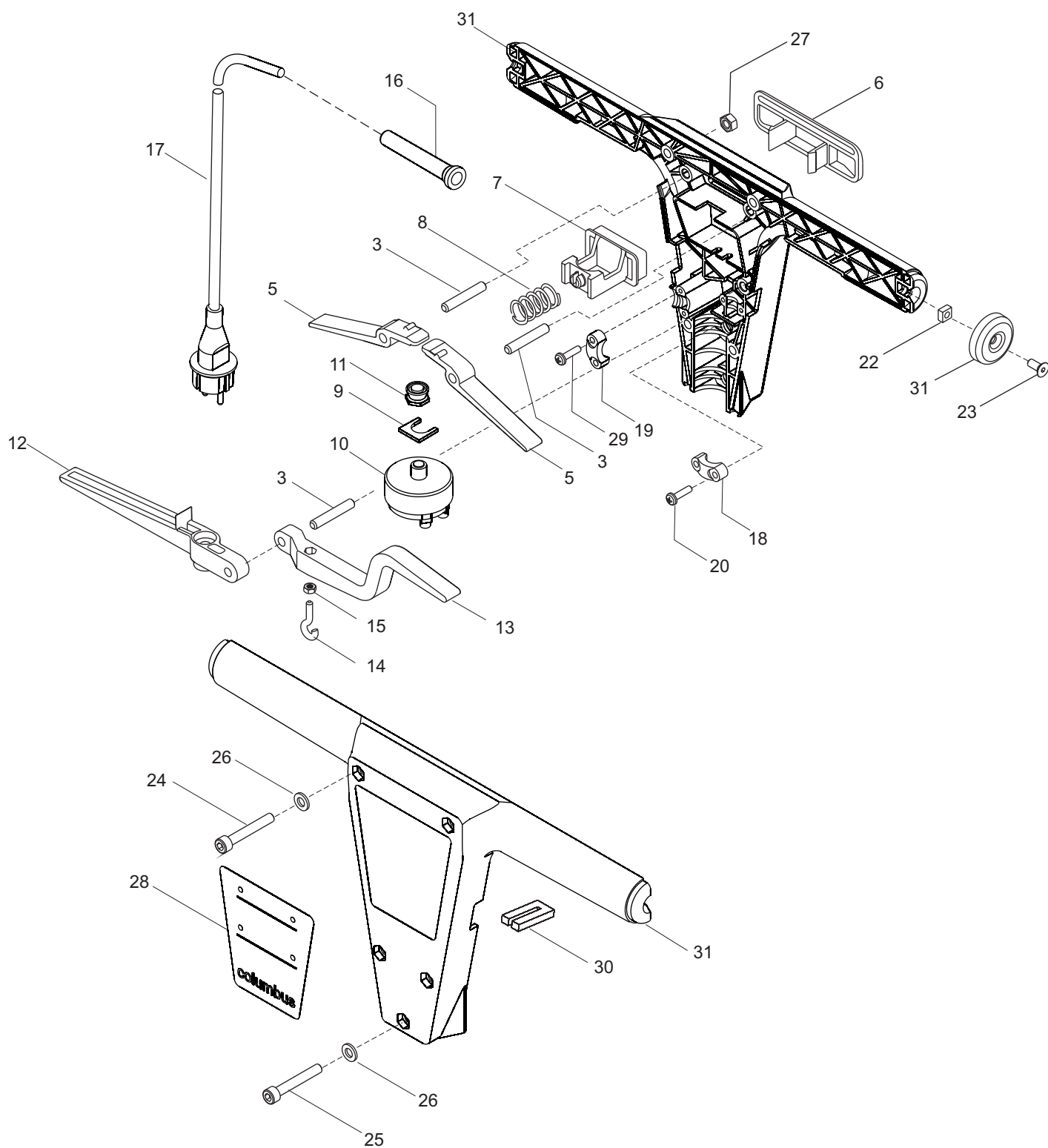

Schalterschalen E 400 | S, E 500 | S, E 500 | E, E 505 | E, HS 403, HS 403 | S, HS 434

Pos	Art.Nr.	Stück	Bezeichnung	Description	Designation	Descrizione
3	20022700	3	Zylinderstift 6M6x36 DIN7	cap screw M6x50	Vis cylindrique M6x40	vite M6x50
5	20896800	2	Schalthebel, rot	connection lever	Levier de commande timon	leva interruttore
6	20040401	1	Druckplatte, blau	pression plate	Plaque de commutation	coperchio pulsante
	20040402	1	Druckplatte, anthrazit	pression plate	Plaque de commutation	coperchio pulsante
7	20040503	1	Taste	push button	Bouton poussoir	Tasto interruttore
8	20040100	1	Druckfeder	tension spring	Ressort	molla di pressione
9	20897201	1	Halter für Schalter	fixing	fixation	fissaggio
10	20930700	1	Geräteschalter 20A	switch	Interrupteur	interruttore
11	20040000	1	Gummikappe f. Drucktaster	rubber cap for switch	Capot en caoutchouc	cappuccio in gomma
12	20026001	1	Stellhebel, rot	position lever	Levier de réglage timon	leva comando timone
13	20896900	1	Wasserhebel, rot	water lever	Levier de commande d'eau	Leva serbatoio
14	20023900	1	Ringschraube M4x15 offen	ring screw M4x15	Vis M4x15	Vite con occhiello M4x15
15	20002600	1	6-Kantmutter M 4 DIN934	hex. Nut M4	Ecrou M4	dado esagonale M4
16	20013900	1	Knickschutztülle Ø12x100	cable sleeve	Douille	passacavo
17	20588800	1	Anschlussleitung 3x1,5x12m, 230V	connecting cable 3x1,5x12m, 230V	Ligne de raccordement 12m, 230V	Cavetto di connessione 12m, 230V
	20038700	1	Anschlussleitung 12m, Schweiz	connecting cable 12m, CH	Ligne de raccordement 12m, CH	Cavetto di connessione 12m, CH
18	20033800	1	Zugentlastungsschelle groß	clamp, big	Attache	morsetto
19	20046200	1	Zugentlastungsschelle klein	clamp, small	Attache	morsetto
20	20046300	2	Blechschrabe BZ4,2x19 DIN7981	tin screw 4,2x19	vis 4,2x19	vite autofil. 4,2x19
22	20029900	2	4-Kantmutter M 5 Ms DIN557	square nut M5	Ecrou M5	Dado quadro M5
23	20002800	2	Senkschraube M5x12 DIN965	screw M5x12	Vis M5x12	vite M5x12
24	20932000	2	Zylinderschraube M6x45 DIN7984	cap screw M6x45	Vis cylindrique M6x45	vite M6x45
25	20567600	3	Zylinderschraube M6x55 DIN7984	cap screw M6x55	Vis cylindrique M6x55	vite M6x55
26	20030100	5	Schnorr Sicherung M6	safety ring M6	Anneau de sécurité M6	rondella sicurezza M6
27	20002000	5	6-Kantmutter M6 DIN934	hex nut M6	Ecrou M6	dado esagonale M6
28	70014600	1	Bedienungsschild	operating plate	Autocollant instructions	etichetta di comando
29	20048000	2	Blechschrabe BZ4,2x16 DIN7981	tin screw 4,2x16	vis 4,2x16	vite autofil. 4,2x16
30	21048000	1	Schutz für Schalter	protection	Protection	protezione
31	20897131	1	Schalterschalen kpl., blau	handle	Poignée	scatola
	20897132	1	Schalterschalen kpl., anthrazit	handle	Poignée	scatola

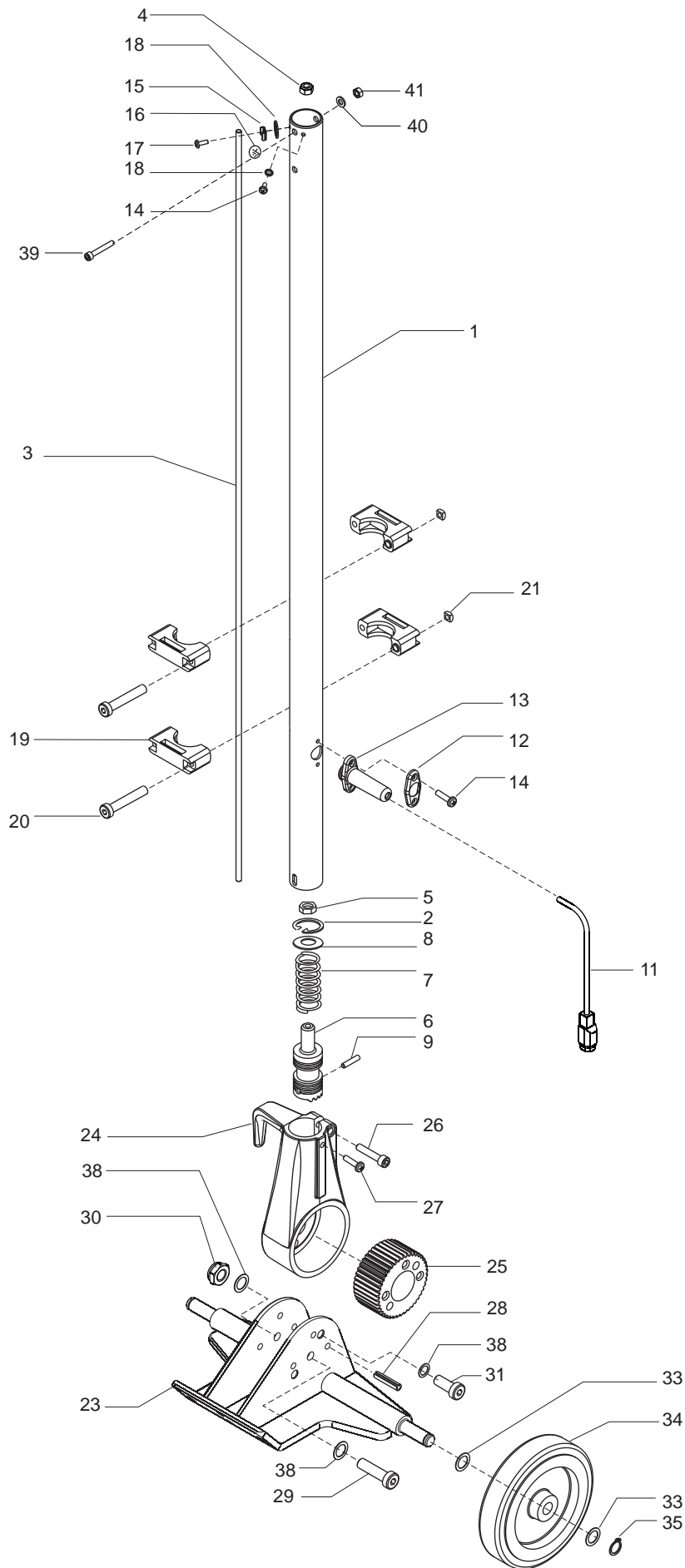

Führungsstange E 400 | S, E 500 | S, E 500 | E, HS 403, HS 403 | S, HS 434

Pos	Art.Nr.	Stück	Bezeichnung	Description	Designation	Descrizione
1	20022806	1	Führungsrohr, blau	tube	Tube timon	tubo timone
	20022802	1	Führungsrohr, anthrazit	tube	Tube timon	tubo timone
2	20030300	1	Sicherungsring I 26x1,2 DIN472	safety ring I 26x1,2	Anneau de sécurité I 26x1,2	seeger sicurezza I 26x1,2
3	20026200	1	Zugstange M5/D5x835	bar	Tige pour timon	perno timone
4	20046000	1	6-Kantmutter M5 Stopp DIN985	hex.nut M5	Ecrou M5	dado esagonale M5
5	20005600	1	6-Kantmutter M 5 DIN934	hex.nut M5	Ecrou M5	dado esagonale M5
6	20025000	1	Rastenstück	catch	Arrêt timon	Pistone dentato
7	20024600	1	Druckfeder D21x30-D2,6	tension spring	Ressort	Molla di spinta
8	20374300	1	Scheibe 13,4x25x3 DIN1441	washer 13,4x25x0,3	Rondelle 13,4x25x0,3	rondella 13,4x25x0,3
9	20179500	1	Spannhülse 4x20 DIN1481	sleeve 4x20	Douille 4x20	Spina elastica 4x40
11	20035200	1	Anschlussleitung 1,25m	connecting 1,250m	Ligne de raccordement 1,250m	Cavetto di connessione 1,250m
12	20008700	1	Flanschnapf	flange	Flange	flangia
13	20008600	1	Kabelmuffe mit Flansch	cable sleeve	Douille	passacavo
14	20036500	2	Linsenschr.DUO-T.CM4x10	screw CM4x10	Vis CM4x10	vite CM4x10
15	20057900	1	Klemmbügel	clamp	Etrier de serrage	morsetto
16	70015400	1	Erdungszeichen	earth sign	Autocollant	contrassegno messa s terra
17	20036500	2	Linsenschr.DUO-T.CM4x10	screw CM4x10	Vis CM4x10	vite CM4x10
18	20060000	2	Sicherungsscheibe SMZ4	lock washer SMZ4	Rondelle SMZ4	rondella di bloccaggio SMZ4
19	20026303	4	Tankträger, rot	tank holder, red	Support de réservoir, rouge	Supporto serbatoio, rosso
20	20030400	4	Zylinderschraube M 5x45 DIN912	cap screw M5x45	Vis cylindrique M5x45	vite M5x45
21	20029900	4	4-Kantmutter M 5 DIN557	square nut M5	Ecrou M5	Dado quadro M5
23	20888801	1	Halterung, blau	support	Support	supporto
	20888802	1	Halterung, anthrazit	support	Support	supporto
24	20025706	1	F-Stangenhalter, blau	catch	Support de timon	morsetto snodo timone
	20025702	1	F-Stangenhalter, anthrazit	catch	Support de timon	morsetto snodo timone
25	20024900	1	Zahnrad	gear	Pignon timon	ingranaggio dentato timone
26	20035700	1	Zylinderschr.DUO-T.EM 6x30	cap screw EM6x30	Vis cylindrique EM6x30	vite EM6x30
27	20543900	1	Linsenschr.EJOT M 5x10 SF	screw M4x10	Vis M4x10	vite M4x10
28	20029000	3	Spannhülse 6x36 DIN1481	clamp sleeve	Douille 6x36	spinotto 6x36
29	20032400	1	Zylinderschraube M 8x60 DIN7984	cap screw M8x60	Vis cylindrique M8x60	vite M8x60
30	20280500	1	6-Kantmutter M8 STOPP	hex.nut	Ecrou	dado esagonale
31	20029200	2	Zylinderschraube M 8x25 DIN7984	cap screw	Vis cylindrique	vite
33	20047400	4	Pass-Scheibe 12x18x0,5 DIN988	washer 12x18x0,5	Rondelle 12x18x0,5	rondella 12x18x0,5
34	20030600	2	Laufrolle Ø125/Ø12	roller wheel Ø125/Ø12	Roulette Ø125/Ø12	ruota Ø125/Ø12
35	20028900	2	Sicherungsring A 12x1 DIN471	safety ring I 12x1	Circlips 12x1	seeger 12x1 sicurezza
38	20067600	4	Scheibe 8,4x17x2	washer	Rondelle	rondella
39	20932000	1	Zylinderschraube M 6x45 DIN7984	cap screw M6x45	Vis cylindrique M6x45	vite M6x45
40	20030100	1	Schnorr Sicherung M6	safety ring M6	Anneau de sécurité M6	rondella sicurezza M6
41	20002000	1	6-Kantmutter M6 DIN934	hex nut M6	Ecrou M6	dado esagonale M6

Pos.	Bezeichnung	Description	Descrizione	Description
1	Schalter	switch	interruttore	interrupteur
2	Steckverbindung	socket connection	spina di contatto	conexion par fiches
3	Arbeitswicklung	working winding	avvolgimento primario	enroulment de travaux
4	Fliehkraftschalter	centrifugal switch	disgiuntore	interrupteur tachymétrique
5	Anlasskondensator	starting condenser	condensatore di spunto	condensateur de démarrage
6	Motor	motor	motore	moteur
7	Hilfswicklung	auxiliary winding	avvolgimento secondario	enroulment auxiliaire
8	Betriebskondensator	condenser	condensatore	condensateur
9	Steckdose	socket	presa	prise de courant

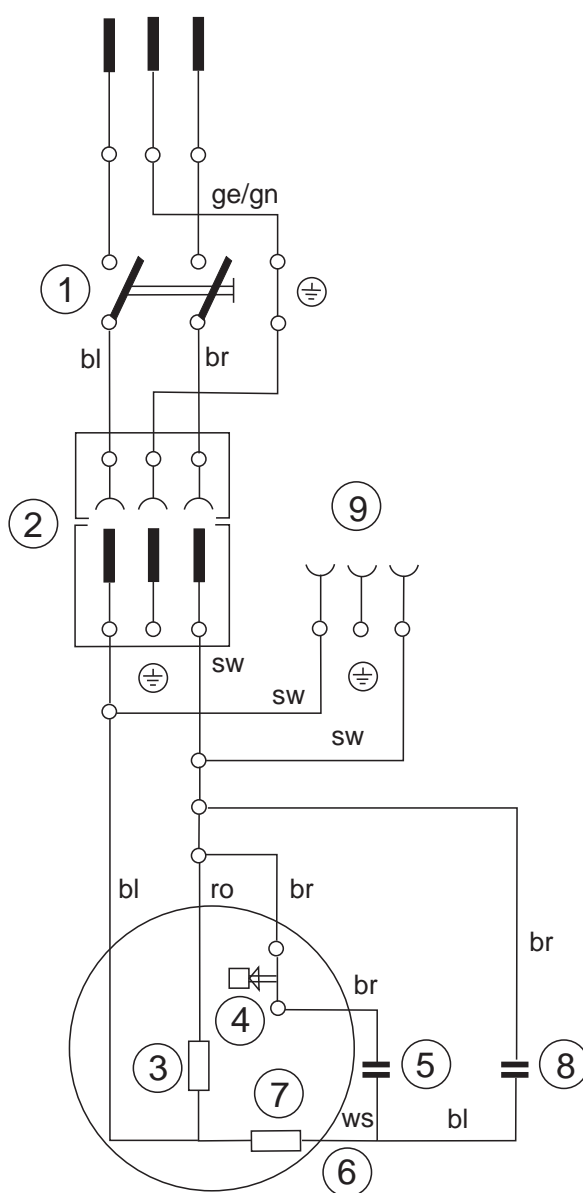

Änderungen im Zuge technischer Verbesserungen sind vorbehalten !
We reserve the right to effect modifications within the framework of technical progress !
Sous réserve de modification dans le cadre des développements techniques !
Essendo la nostra un'impresa a carattere innovativo, ci riserviamo la possibilità di apportare modifiche tecniche !

G. Staehle GmbH u. Co. KG
columbus Reinigungsmaschinen
Mercedesstr. 15
D - 70372 Stuttgart
Telefon +49(0)711 / 9544-950
Telefax +49(0)711 / 9544-941

info@columbus-clean.com
www.columbus-clean.com

columbus